

Background

South Africa has been plagued by power shortage for years. The main power source is coal power, short supply of the coal resource leads to high electricity price. Due to the long-distance transmission, approximately 10-12% of the power is lost during the process. Some people living in poor power condition would have to turn to diesel generators. However its high cost and harmful emissions makes it the last choice in the long run. Solar power, being environmentally-friendly and not affected by transmission power loss, has been popularizing by the South African government, and many households and businesses have put solar panels on their rooftop. Meanwhile as a trend for solar industry, energy storage system has also attracted more eyes of local customers.

In South Africa, tourism is one of the booming industries, which contributes to 8.7% of the country's GDP and 1.4 million employments. In Mohondoro resort, an ATESS storage system system has been installed, and now let's take an insight of this project.

Site Survey	
Site location	Breede Valley Municipality
Grid condition	Unstable
Load	160kW
PV installation	230kWp
Equipment installation	Indoor

System solution

Previously, the customer installed a 200KVA diesel generator on site to keep the equipment running. Not only to solve the problem of power shortage and high cost, but also to obtain profits from peak-valley electricity prices gap, the client went for a solar storage system supplied by ATESS. The system will use solar as the main energy source to supply power for the load and charge the battery. During peak hours, the electricity stored in the battery will be sold to utility grid to gain revenue. As the emergency backup power sources, diesel generators will be automatically turned on only when neither solar, grid, or batteries are able to supply. Then when the battery is charged to a certain degree or the grid returns to normal, the system will automatically switch over to other power sources (solar, grid or battery).

System Configuration		
PV	230kWp	
ATESS HPS120	2*120kW Hybrid inverter in parallel	
ATESS ATS240	240kW Automatic transfer switch	
ATESS PV-CB16M	2*16-channel PV combiner box	
ATESS ShineMaster	Monitoring datalogger	
ATESS DC combiner	For combination of multiple battery racks	
Battery	Type	LFP
	Capacity	1MWh, 90%DOD@>5500 cycles
	Configuration	624V*800Ah*2

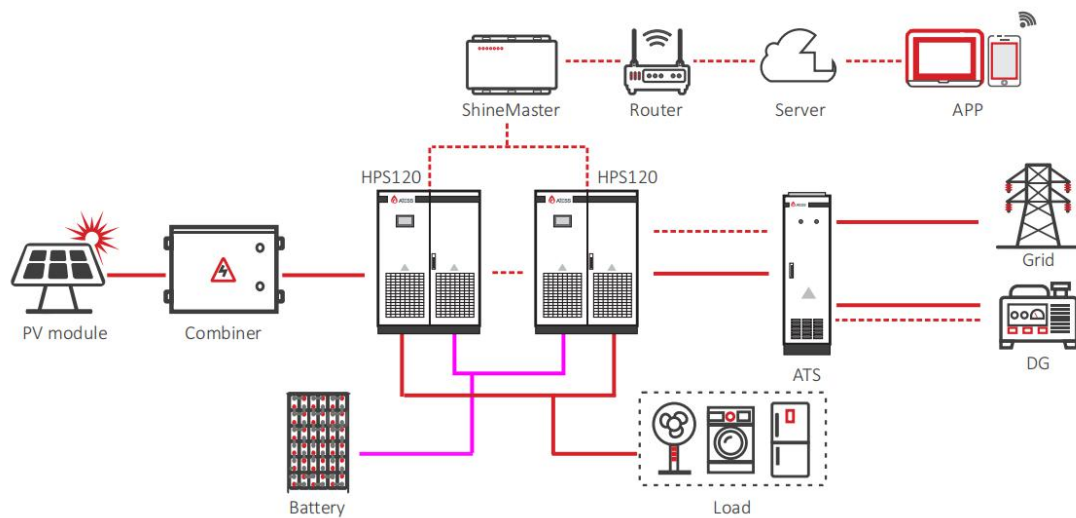

System features

The peak load on site reaches 160kWp, and there are a few inductive loads, like air conditioners and water pumps. So we decided to link two units of the 120KW model HPS120 in parallel. With the parallel feature, the rated power of the entire system can fully meet the client's demand. The maximum PV capacity that each HPS120 can be connected to is 180kWp, and for two units that is 360kWp, so it also reserves the possibility for system expansion in the future. What's more, we offer smart monitoring system that includes ShineMaster and smart cloud. ATESS ShineMaster enables users to monitor and manage multiple devices online. And ATESS PV combiner box can connect multiple strings of PV modules to the inverter, upload data to the server so as to monitor the power of each PV string. Additionally, communication between ATESS ATS and HPS tells whether it's grid or DG that connected to the system, and realize seamless switch between multiple operation mode (grid-connected, off-grid and diesel generator). It is worth mentioning that through dry contact signal that sent by HPS, the system is able to fulfill automatic DG start-stop function.





Operation mode

Grid-connected mode

1. During Valley hours:

- a) When the PV power is greater than the charging power, charge battery first, and the remaining to the load.
- b) When the PV power is less than charging power, charge battery first, and the grid supplies the load while charging the battery.

If there is no discharging or mode switch in the grid-connected backup mode, in order to maintain electrochemical activity of the battery, the battery will enter the battery discharge state after one week of current limiting charging, and the battery discharge power is 20% of the rated output power.

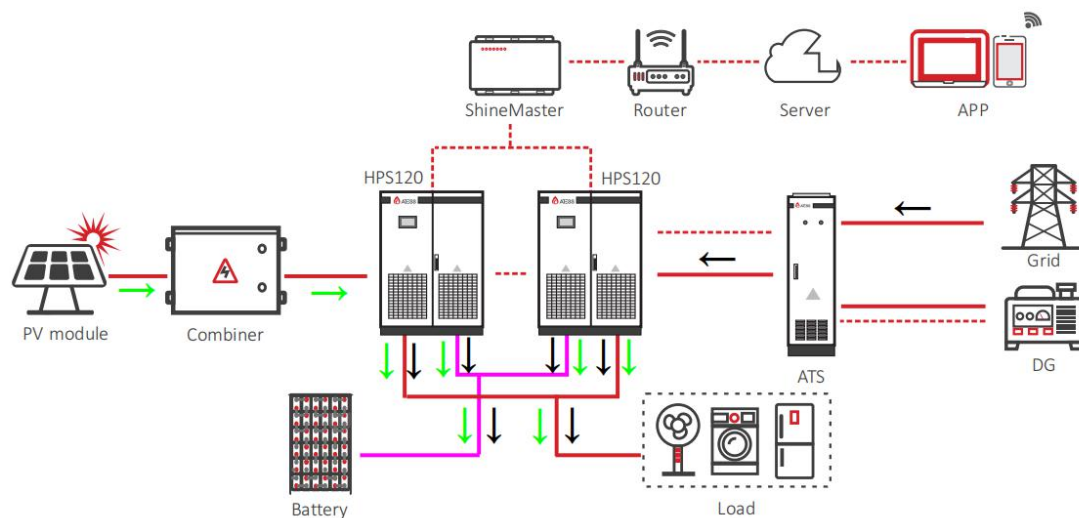

2. During fair hours:

- a) The battery does not discharge, and the grid does not charge the battery.
- b) When PV power is greater than the load, supply to load first, and the remaining charge the battery.
- c) When PV power is less than the load, PV and grid supply the load jointly, and PV does not charge the battery.

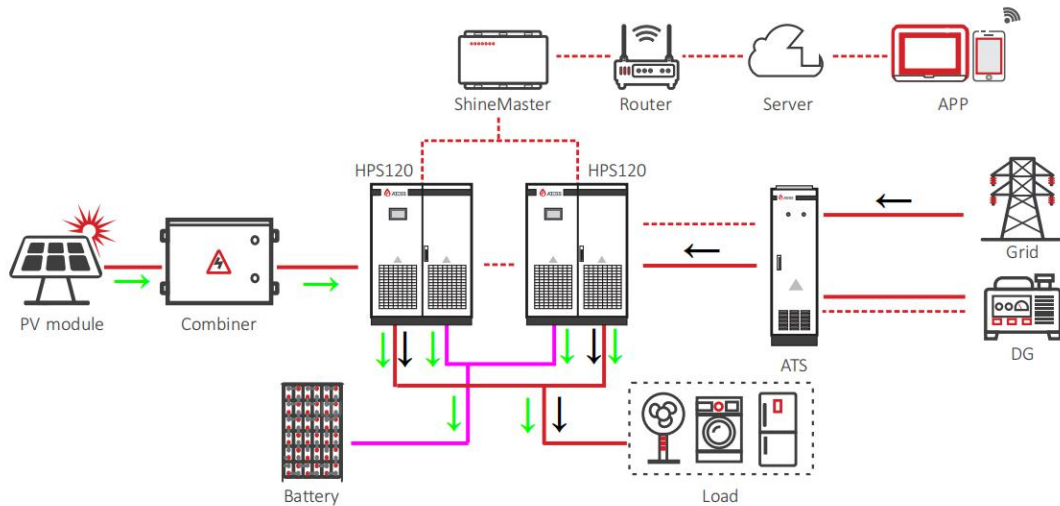

3. During peak hours:

- a) The grid does not charge the battery
- b) When PV power is greater than the load, PV supplies to the load first, and the remaining charge to battery.
- c) When PV power is less than the load, there are two situations:
 - (1) When battery voltage is normal, PV and battery supply for load together.
 - (2) When battery voltage is low, the battery stops discharging. PV and grid supply the load jointly, and do not charge the battery.

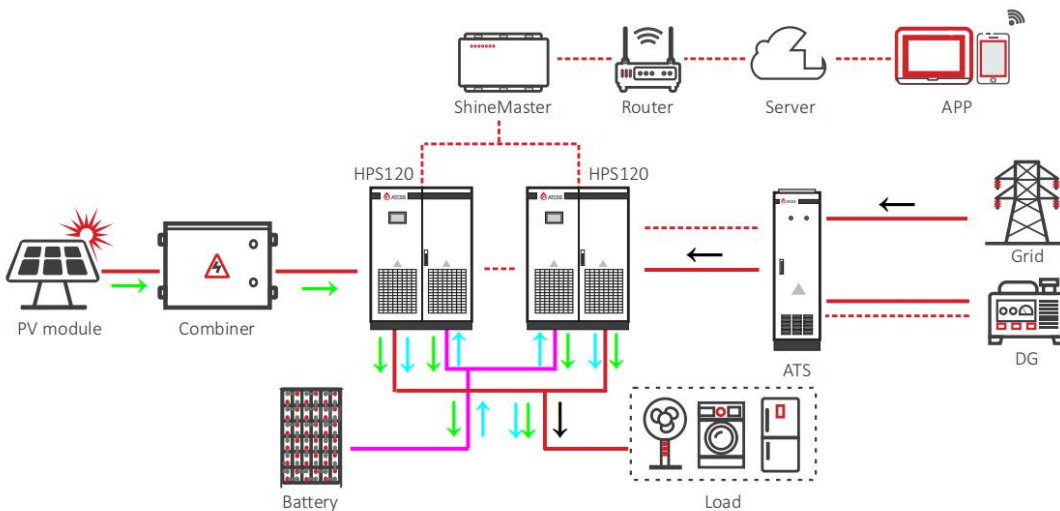

Off-grid mode

When grid fails, the system switch to off-grid mode automatically with no power supply interruption and operates following below procedure:

1. When PV power is greater than load power, PV supplies to load first, and the remaining charge to battery.
2. When PV power is insufficient for the load, the battery automatically discharges.

When battery is discharged to the undervoltage protection point, there will be the following two situations:

- a) In the default setting, the inverter stops working and switches to PV charging mode.
- b) If the engine access function is enabled, HPS will send a relay signal to start the generator, and it will be responsible for load supply or battery charging.

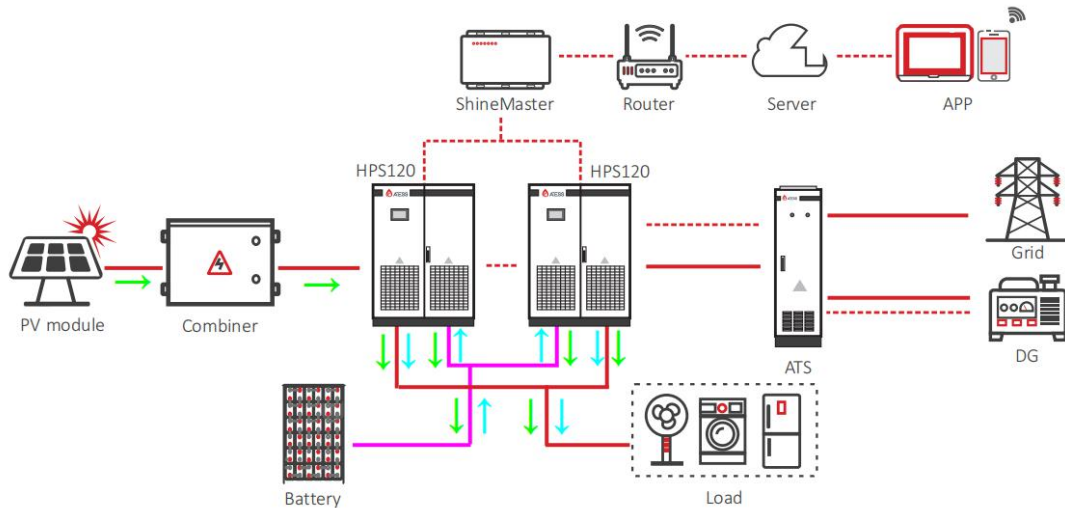

DG mode:

When the battery is discharged close to the undervoltage alarm point and the power grid fails, the HPS sends a dry contact signal to start the diesel generator, and the generator supplies power to the load; In the meantime, HPS stops supplying power to the load and only charges the battery.

- (1) When PV power is greater than the charging power, PV power is only used to charge the battery.
- (2) When PV power is less than the charging power, charge battery first; generator supplies for the load, and charge the battery optionally.
- (3) After the battery is fully charged, HPS sends a signal to stop the diesel generator and switch to off-grid mode.

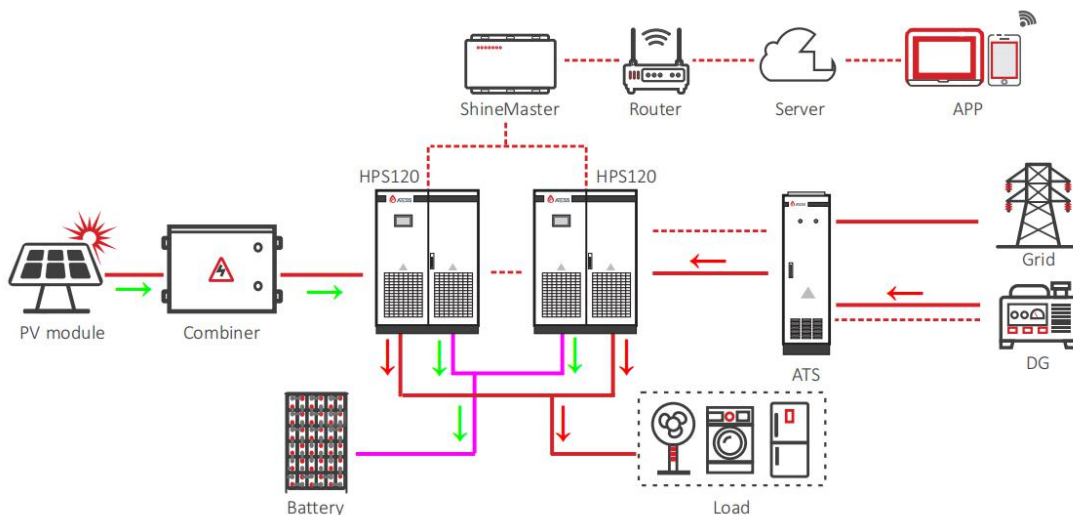

System operation summary

Under guidance from the ATESS after-sales team, the system has been commissioned and started running from July 2020. With simple operation and user-friendly GUI, the user has obtained a great using experience. Until now, the diesel generator has never been turned on, and grid power consumption has been reduced to 10% of that before installation. Through selling the exceeded power to grid, the client has also gained a decent amount of profit. Overall, the system has fully utilized renewable energy and created significant socio-economic benefits for the client.

Committed to clean energy innovation, ATESS has been delivering high-quality products, all-rounded services and customized solutions since 2013. As a professional ESS and EV charger provider, we will keep on making greater contribution for a greener world.