



SHENZHEN ATESS POWER TECHNOLOGY CO.,LTD

GROWATT-ATESS Industrial Park, No.23 Zhulongtian Road, Shuitian Community,
Shiyan Street, Baoan District, Shenzhen

Tel: +86 755 2998 8492

Web: www.atesspower.com

Email: info@atesspower.com

Revised date: 2026-05-19

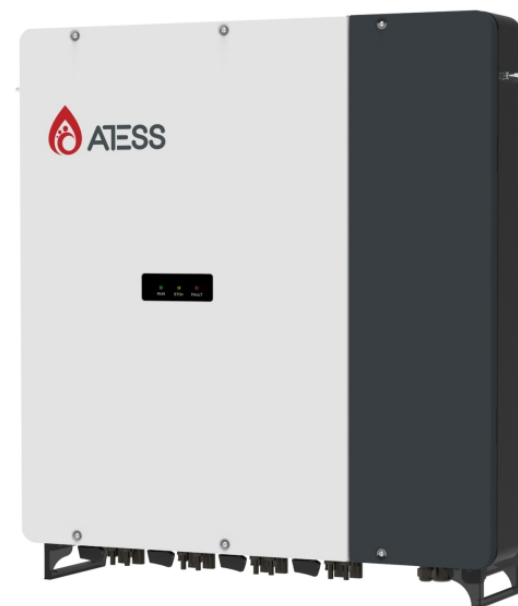

ATESS SMC200
Solar Charge Controller
User Manual

Contents

1 About this Manual

- 1.1 Content Introduction
- 1.2 Target readers
- 1.3 Manual usage

2 Safety Notice

- 2.1 Symbol Instructions
- 2.2 Usage Notice
- 2.3 Correct installation method
- 2.4 Operator
- 2.5 Important precautions

3 Product Description

- 3.1 Optical Storage System
- 3.2 Electrical Principle of Controller
- 3.3 Layout of main parts
- 3.4 Operating mode
- 3.5 Notice of load usage
- 3.6 Size and weight
- 3.7 Packaging Information

4 Product transportation and storage

- 4.1 Transportation of the product
- 4.2 Inspection and storage of the products

5 Product Installation

- 5.1 Requirements for installation conditions
- 5.2 Tools and spare parts required for the installation
- 5.3 Mechanical Installation
- 5.4 Electrical Installation
- 5.5 Communication
- 5.6 Single-parallel system wiring with CAN communication wiring

6 Initial Power On

- 6.1 Pre-operation Inspection
- 6.2 Power On

7 Man-Machine Interface

- 7.1 Introduction to Touch Screen
- 7.2 Upper computer operation
- 7.3 LCD Display Information Schedule

8 Operation

- 8.1 Startup and operation steps
- 8.2 Complete the trial run
- 8.3 Shutdown and power-off steps

9 Product Maintenance

- 9.1 Routine Maintenance
- 9.2 Waste Disposal

10 Accessories

- 10.1 Product Specifications
- 10.2 ATESS Factory Warranty

1 About this Manual

The purpose of this chapter is to provide an overview of the manual's content and target audience, facilitating users' comprehension of its contents.

1.1 Content Introduction

The present manual is applicable to the ATESS SMC200 solar charge controller products (hereinafter referred to as SMC200). It encompasses the following key contents:

- **Safety Notice**

The safety concerns related to SMC200.

- **Product Description**

The function, structure, and principle of SMC200, as well as the size and packaging of SMC200, along with its operational mode and other relevant information.

Product Transportation and Storage

The transportation mode of the product and the storage-related precautions.

- **Product Installation**

Conditions for SMC200 installation, required tools, mechanical and electrical installation of SMC200, communication connections, and other relevant information.

- **The product is powered on for the first time**

The information regarding essential procedures to be conducted during the initial power-on of the SMC200.

- **Man-machine interface operation guide**

Interface display information of the LCD touch screen for SMC200, operation setting method and other information.

- **Operation**

Information such as SMC200 startup and shutdown steps.

- **Product Maintenance**

Routine maintenance of SMC200, waste disposal and other information.

- **Attachments**

The technical data, quality assurance terms, and contact information of SMC200.

1.2 Target readers

The applicable personnel should possess the following qualifications:

- Only professional electricians or individuals with professional certifications are authorized to carry out transportation, installation, and other operations of this product;
- The operators must have a comprehensive understanding of the composition and working principle of the entire energy storage system.
- The operators should be fully acquainted with the user manual for this product;
- The operators should be fully familiar with the relevant standards of the country/region where the project is located.







1.3 Manual usage

Before installing or using the equipment, it is essential to thoroughly review this manual. It is recommended to keep this manual and relevant information readily accessible alongside the product components for easy reference by authorized personnel. Please note that the contents of this manual will be continuously updated and revised; therefore, there may be occasional inconsistencies or errors with respect to the actual product. The purchased product shall prevail over any discrepancies found herein. For further assistance, users can contact the local distributor or access the latest version of this manual through our website www.atesspower.com.

2 Safety Notice

2.1 Symbol Instructions

In order to ensure the safety of users' personal belongings and property during installation, as well as to maximize the efficiency and optimal usage of this product, pertinent information is provide in the manual emphasized through appropriate symbols. The following enumerates the symbols that may be utilized this manual. Please carefully review them to enhance your utilization of this manual.

	DANGER DANGER indicates a hazard with a high level of risk which, if not avoided, will result in death or serious injury.
	CAUTION CAUTION indicates there is potential risk, if not avoided, could result in equipment malfunction and property damage.
	Caution, risk of electric shock When battery bank connecting point are exposed, there will be DC voltage in the equipment DC side; and when output breaker is on, there is a potential risk of electric shock.
	Caution, risk of fire hazard Suitable for mounting on concrete or other non-combustible surface only.
	Protective conductor terminal The inverter has to be firmly grounded to ensure the safety of personnel.
	Risk of electric shock, Energy storage timed discharge Electrical shock danger exists in the capacitor; the cover shall be moved at least 5 minutes later after all powers are disconnected.

2.2 Usage Notice

All SMC200 installation and service personnel must undergo training to ensure their familiarity with general regulations for working on electrical equipment. Additionally, they should be well-versed in safety codes and requirements.

- Prior to usage, it is essential to thoroughly read this manual. Failure to operate the equipment according to the instructions provided may result in a void of quality assurance by the company.

- Only qualified electrical engineers are permitted to operate SMC200 devices.
- While the device is operational, refrain from touching any other electrical components except when necessary checking device operation information via the display screen.
- All electrical operations must adhere to local standards for electrical operations.
- The utilization of on-grid SMC200 charge and discharge requires authorization from the local power supply department and should only be carried out by professionals.

2.3 Correct Installation Method

The proper installation of a SMC200 entails adhering to all instructions outlined in the owners' manual pertaining to equipment transportation, installation, electrical connection, and operation. ATESS shall not be held liable for any damages resulting from improper usage of the equipment.

The SMC200 possess an IP65 protection progress and is specifically designed for indoor installations. During the installation process, it it imperative to carefully review the information provided in the user manual, particularly Chapter 5 titled "Product Installation".

Additionally, ensuring appropriate utilization of the equipment necessitates attentiveness towards:

- Acknowledging safety instructions listed herein and below;
- Heeding guidelines presented within the SMC200 user manual;
- Considering technical data associated with this device.

2.4 Operator

Only electricians who have received training and approval from the power supply company are authorized to install and conduct test runs on a SMC200. Prior to installation, all installation and service personnel must undergo training and become familiar with the fundamental safety requirements for operating electrical equipment. Additionally, installation and service personnel should be knowledgeable about relevant local regulations and safety protocols.

2.5 Important Precautions



Note1: Static electricity can cause damage to SMC200

Due to the electrostatic discharge, it has the potential to result in irreversible damage to the internal components of SMC200.

Note2: Usage restrictions

Direct connection of life AIDS and medical devices with SMC200 is prohibited!

Note3: Tool precautions

Prior to powering on, thoroughly inspect for any installation tools or other unnecessary items left inside the SMC200.

Note4: Maintenance precautions

Ensure the SMC200 has been safely powered off during maintenance and all live machine components have been discharged before proceeding.

3 Product Description

3.1 Optical Storage System

The SMC200 series, manufactured by ATESS, is a solar charge controller system designed to efficiently distribute photovoltaic direct current to energy storage batteries. Currently, the SMC200 is predominantly utilized in conjunction with PCS energy storage systems, as illustrated in the following diagram:

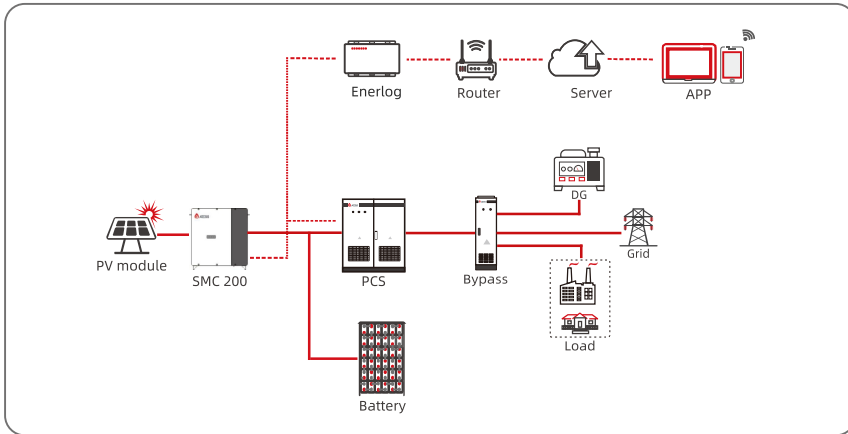

SMC200+PCS+bypass system diagram

3.2 Electrical Principle of Controller

The SMC200 is a first-level BUCK step-down circuit designed to match the battery output and utilize voltage reduction for efficient battery charging.

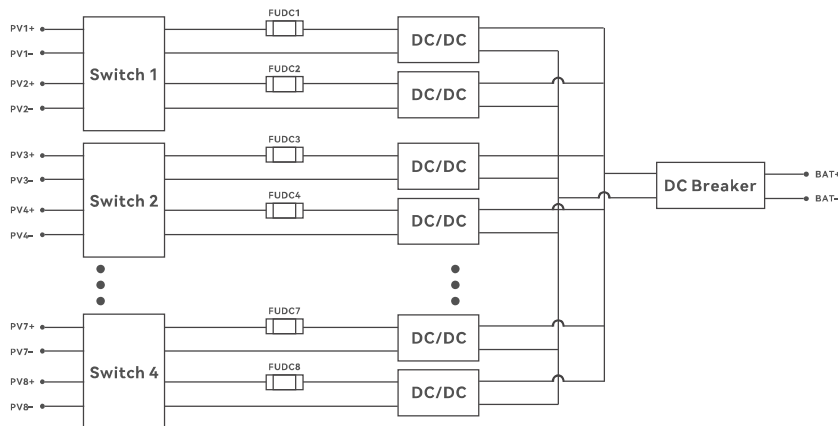

Electrical Schematic Diagram of SMC200

3.3 The layout of the main components

3.3.1 External components

The main external components of SMC200 include: LED indicator lights, disconnectors, PV terminal blocks, etc.

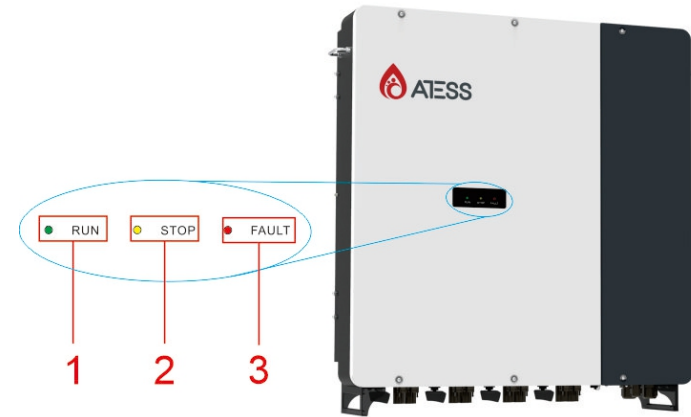

Figure 3-3-1-1 Exterior description of a SMC200

S/N	Part Name	Description
1	RUN indicator	When the SMC200 system is running, this indicator is on, bright green
2	FAULT indicator	When the SMC200 fails to work, the indicator lights up and turns red
3	STOP	This indicator is always on when the SMC200 is waiting or checking

Figure 3-3-1 Part description

Indicator

This SMC200 features an intelligent design. At the top of the inverter power supply are three LED lights that show the main operating status of the machine. The current working status of the SMC200 can be seen through the LED indicator lights.



Figure 3-3-1-2 Equipment operation indicator LED

LED	Meaning
RUN	The indicator light is always on when the SMC200 system is running
STOP	When the SMC200 is in the waiting or checking state, this indicator light remains on constantly
FAULT	The indicator light stays on when the SMC200 fails to work

Table 3-3-2 LED operating status

3.3.2 Internal Components

The internal components of SMC200 include: disconnectors, output circuit breakers, PV lightning protection, PCB boards, etc. The following are pictures of the internal components on the front and back of the SMC200.

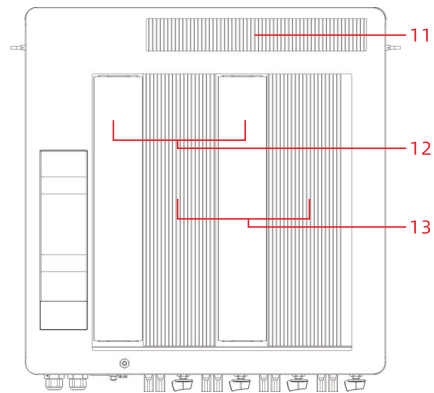
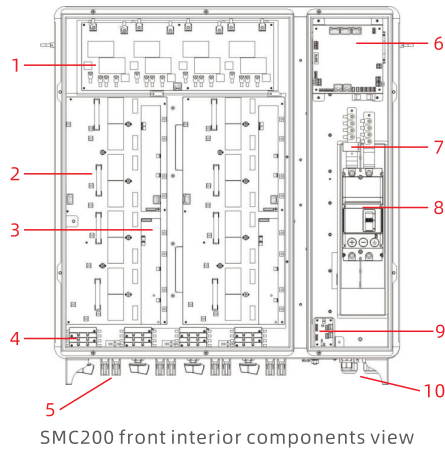

Model	SMC200	
Serial number	Part Name	Instructions
1	Output capacitor board	Output filter capacitor
2	BUCK power board	Achieve PV voltage reduction
3	BUCK drives the power board	Provide drive power to the power board
4	PV disconnector	Control the disconnection of the PV from the machine
5	PV MC4 interface	PV input, connect to the PV module interface
6	Control panel	Main control board
7	Output current sampling hall	Sample the total output current
8	Battery circuit breaker	Control the disconnection of the battery from the machine
9	Interface board	Communication interface
10	SMC200 Output interface	Connect the battery
11	Output the anti-reverse radiator	Cool the output anti-reverse diode
12	Potting inductor heat sink	Cool the potting inductor
13	IGBT heat sink	Cool the output IGBT

3.4 Operating mode

Currently, the operation mode needs to be used in conjunction with the PCS energy storage machine, the SMC200 output terminal is connected to the PCS bus terminal for use, and the mode selection needs to be selected on the PCS screen. The SMC200 itself does not have a battery.

3.4.1 Failure Mode

When the SMC200 fails, the circuit breaker on the output side will be immediately disconnected and shut down to enter the fault state, thus ensuring system safety. At this time, the SMC200 will continuously monitor whether the fault has been eliminated, and if the fault has not been eliminated, it will remain in a faulty state; After the fault is eliminated, you can restart.

3.4.2 Permanent Failure Mode

When a relatively serious fault occurs in the SMC200, the SMC200 power supply will immediately open the output circuit breaker and enter a permanent fault state to ensure the safety of the system. When permanent fault information is detected three times in a row, the output circuit breaker will be disconnected. For example: Information such as a fault in the SMC200 module of the SMC200. Generally, when the SMC200 enters this permanent failure mode, do not repair the SMC200 on your own. Instead, contact the local dealer or call Shenzhen ATESS Power Technology Co., Ltd. for assistance.

3.4.3 Abnormal output power

When the ambient temperature is too high, the output power of the storage SMC200 will normally decrease. However, if this happens frequently, check the cooling surface of the SMC200 or place the SMC200 in a well-ventilated area. If the SMC200 fan is dirty, clean the fan dust, and if there is a problem inside the SMC200, seek help from a professional service department.

3.5 Notice of load usage

Nowadays, the SMC200 series are all used in conjunction with PCS energy storage machines. The SMC200 only outputs DC, and the output end needs to be connected to the PCS bus for voltage stabilization in order to be used normally. Remember: SMC200 cannot operate without PCS output terminals.

Model	SMC200
Rated power (KW)	180
DC load MAX (KW)	200

If the DC load power is greater than the rated output power of the selected model, multiple SMCs in parallel are recommended.

3.6 Size and weight

Model	SMC200
Dimensions (width * height * thickness)	838*764*215mm
Weight	65kg

Table 3-8 SMC200 sizes

3.7 Packaging Information

Serial number	Name	Units	Quantity	Notes
1	SMC200 complete machine	PCS	1	
2	User Manual	PCS	1	
3	Certificate of conformity	PCS	1	
4	Factory test report	PCS	1	

4 Transportation and Storage

4.1 Transportation of the product

When transporting the SMC200, the user is only permitted to use the transportation method described in the user manual.

4.2 Inspection and storage of the product

The user should carefully inspect the SMC200 delivered by the shipping company before signing for it. Inspect the received items against the items listed in the delivery notice. If any defects or damages are found, notify the shipping company immediately and ask it to appraise the equipment. You may seek assistance from Shenzhen ATESS Power Technology Co., Ltd. if necessary.



Attention!

This device can only be stored in a package, so make sure it is dust-proof and moisture-proof inside. If it is to be stored for a long time, the SMC200 must be kept in a dry environment to prevent water from entering the SMC200.

5 Product Installation

5.1 Requirements for installation conditions

To ensure the machine works properly, the installation environment and requirements are as follows:

- This SMC200 has a protection rating of IP65, and the product is an electronic device, so do not place it in damp areas;
- Outdoor installation is permitted, but avoid direct sunlight and rain as much as possible;
- Good ventilation around the machine;
- Install away from bad environments such as sand, dust, corrosive gases, etc.
- The equipment will generate some noise during operation, so it should be installed away from residential areas as much as possible;
- Install the ground to ensure it does not shake, and the support surface should meet the load-bearing requirements of the SMC200;

- The installation location should be ensured to be easy to maintain;
- Ambient temperature between -25°C and 55°C ;
- The machine should reserve sufficient space for ventilation and heat dissipation.
- Wall requirements

This SMC200 is required to be mounted on a flat wall with a flame-retardant surface or a channel steel support structure, and the wall must not be dented or tilted. It is necessary to ensure that the wall is solid and secure. The wall must have the capacity to bear the weight of the SMC200.

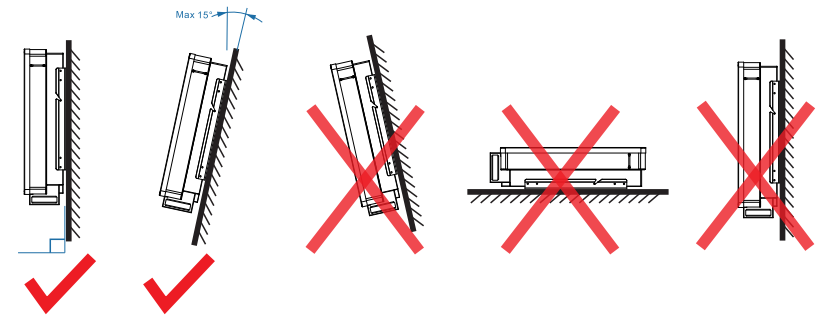

- Space requirements

When installing the SMC200, the distance from the top of the SMC to the eaves exceeds 600mm.

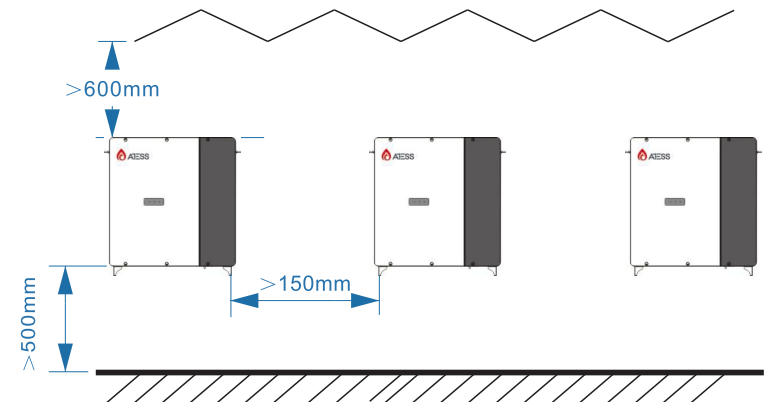



Warning!

When the environmental temperature is too high, inverter derating is a normal operation. However, if derating occurs frequently, please check the inverter's heat dissipation surface or consider relocating the inverter to an area with better ventilation. If the fan is dirty, please clean it. If an inverter has an internal fault, please seek professional service.

● Cables requirements

Power cables and communication cables should be placed separately in different cable trenches to prevent them from running parallel over long distances and to reduce electromagnetic interference caused by output voltage transients. The distance between power cables and communication cables should be greater than 0.2m. When the wires are crossed, the crossing Angle should be 90 degrees, and the distance can be appropriately reduced.

● Ventilation requirements

SMC200 generates heat during operation, and when the ambient temperature is too high, it can affect the electrical performance of the equipment and even damage the equipment, so the release of this heat needs to be fully considered in the design of the control room to ensure the normal and efficient operation of the equipment.

● Ventilation environment

To meet the ventilation requirements of the SMC200, the installation environment must meet the following conditions:

- 1.SMC200 should avoid being installed in places with poor ventilation and low air flow;
- 2.The air intake should have sufficient air supply.

● Ventilation equipment

To ensure the safe, reliable and efficient operation of the equipment, the ambient temperature of the equipment must be within the range of -25 °C to 55 °C. Therefore, appropriate ventilation devices should be provided to dissipate the heat generated by the equipment. It is recommended that the ventilation volume of the SMC200 installation space be at least 50m³/h;

1. The distribution room must be equipped with ventilation facilities to ensure that the waste heat generated by the SMC200 can be discharged from the equipment to meet the maximum allowable ambient temperature. This can be achieved by installing exhaust devices such as fans, ventilation ducts, etc.
2. To ensure balanced pressure, a fan for outward exhaust can be added at the outlet of the air duct;
3. The direction of the outlet should be chosen according to the actual wind direction of the local area;

4. Pay attention to the dust prevention measures and rain protection design of the air inlets and outlets;

5. If ventilation ducts are needed, the size of the ducts should be based on the volume of air outlet and should be designed by a professional.

● Other protection

SMC200 has a protection rating of IP65 and is suitable for installation in a dry, clean power plant environment. Also note Avoid water leakage in the house from damaging the SMC200. According to EMC requirements and noise levels, SMC200 should be installed at work in an industrial environment.

5.2 Tools and spare parts required for the installation

The tools and parts required for installation are as follows:

- Torque wrench;
- Screwdriver;
- Wire strippers;
- Terminal crimping machine;
- Hot hair dryer;
- Megohmmeter and multimeter.

5.3 Mechanical Installation

● Relevant notes

SMC200 is transported as a whole, and users can lift it from the bottom by forklift or move it by crane or hoist.

● Relevant notes

SMC200 is transported as a whole, and users can lift it from the bottom by forklift or move it by crane or hoist.

Note 1: The SMC200 is a whole and must not be disassembled either during transportation or installation. Faults caused by unauthorized modifications are not covered by the warranty.

Note 2: The SMC200 should not be tilted, shaken violently or subjected to sudden force during movement, such as sudden lowering or lifting.

Note 3: Read the marked parameters carefully to select the appropriate means of transportation and storage location.

It is recommended that users use forklifts to move the SMC200 as much as possible.



Before moving the SMC200 cabinet to the intended position, it is recommended to lay the DC input and AC power cables first, as these cables are relatively thick and it will be difficult to lay the cables once the SMC200 cabinet is installed.

In order to ensure that the SMC200 is in a better state of protection during transportation, transport with packaging as far as possible, and follow the package Loaded with a variety of signs for transport, packaging signs illustrated as follows:

ICONS	A sign
	Face up, no SMC200 horizontally, tilted, or upside down
	Handle with care to avoid damage to SMC200 caused by too intense collision friction in the transportation environment
	Take care against moisture to protect your SMC200 from rain or moisture

The unopened SMC200 can be moved using a forklift, a crane fork, or a crane. When moving, pay attention to the weight marked on the packaging to ensure that the forklift, crane fork, or crane has sufficient carrying capacity. The center of gravity of SMC200 is symmetrical front and rear, left and right, and is located at the lower part. During transportation, support or lifting points should be reasonably arranged.

The vehicle transportation method is the standard transportation method. During transportation, the center of gravity of the box should be between the two forks of the forklift. Since SMC200 is large in size and may block the driver's view, it should be assisted by personnel.

5.3.2 Transportation without packaging

● Remove SMC200 packaging

Please follow the steps below to remove the equipment shipping packing box.

Step 1: Open the upper cover of the packaging carton;

Step 2: Remove the paper corner protectors at the four corners inside the package;

Step 3: Take out the equipment wrapped with pearl cotton.

1) Hold the middle position of the equipment;

2) The equipment can be separated by removing the pearl cotton.

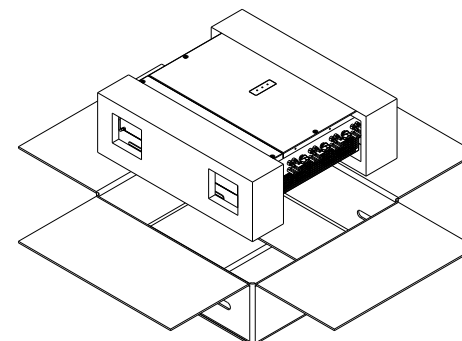

step1

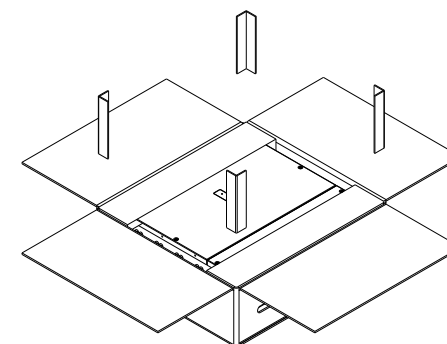

step2

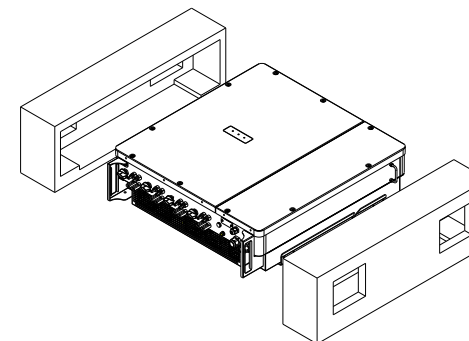

step3

5.3.3 Installation of wall-mounting kit



Before installing the wall-mounting kit, please check and make sure there's no electric cable and gas pipe in the location of installation.

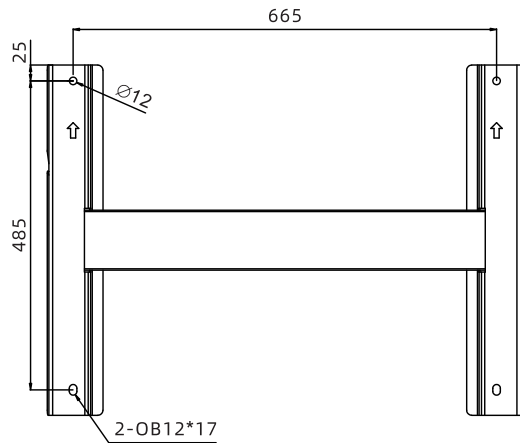

Figure 5-3-3-1 Installation gap

Steps:

- A: Please drill the hole according to the hole mask.
- B: Please install the expansion bolt as shown.
- C: Please install the wall hanger as shown in the picture.

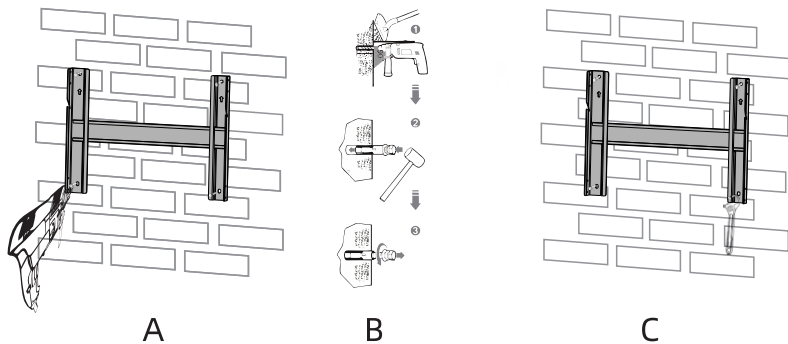

Figure 5-3-3-2 bracket installation



Note: wall-mounting bracket must be installed first before installing SMC200

● Move and install the bare machine

SMC200 that have been unpacked can be lifted and moved by two people. If the unpacking site is a little far from the final installation location, it can be moved with the carton first.

If the SMC200 cartons have already been removed, during transportation, the center of gravity should be placed between two people before lifting and handling, as shown in the picture below:

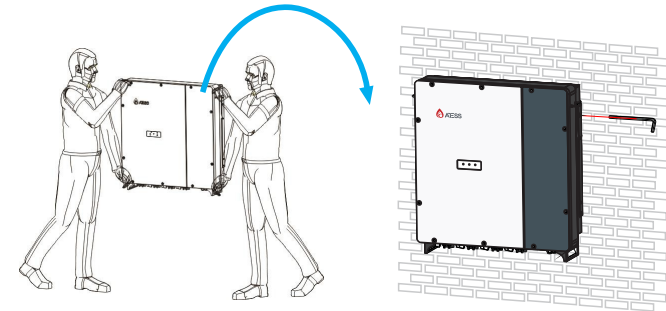

Figure 5-3-3-3 Hanging of SMC200

If using the lifting method for movement, pay attention to the lifting position, ensure that the Angle between the lifting Angle lines is less than 70° , and pay attention to the center of gravity position of the SMC200.

Note:

- Always keep an eye on the center of gravity of the SMC200;
- Take necessary auxiliary measures to ensure the safety of transporters;
- Take necessary auxiliary measures to ensure that the equipment is delivered intact to the final installation site.

5.4 Electrical Installation

5.4.1 Input and Output Requirements

Danger!



- There is a high voltage shock hazard when SMC200 is working, and only electricians with professional skills are allowed to operate SMC200.
 - All operations connected to the equipment must be carried out without voltage.
 - If the input and output terminals are connected incorrectly, the SMC200 will be damaged!
- Failure to follow this warning may result in serious personal injury or significant property damage, or even death.

● Battery assembly

The open-circuit voltage between the positive and negative terminals of the SMC200 battery assembly should not exceed 850V. If it does, it will put the equipment in an overvoltage protection state and prevent it from functioning properly.

● Cable Requirements

Model	SMC200
PV	Bus diameter per route:4mm ²
Out put	Bus diameter per route:95mm ²
Ground wire	6mm ²
Communication wire	Shielded wire: 0.5mm ²

5.4.2 DC side wiring

Danger!



SMC200 only has DC input and output, it is necessary to ensure that the positive and negative poles are not reversed. After determining the polarity with a multimeter, the corresponding positive and negative pole input terminals or output terminals should be connected to the SMC200; The internal power supply of SMC200 is on the upper end of the circuit breaker.

The DC side connection method is as follows:

Step 1: Disconnect the upper DC side distribution circuit breaker to ensure that the DC side connection is not live.

Step 2: Use a multimeter to measure the open-circuit voltage of the battery assembly to ensure it is within the allowable range.

Step 3: Use a multimeter to confirm the positive and negative terminals.

Step 4: Remove the insulation at the ends of the cable.

Step 5: Crimp the copper nose of the cable.

1. Insert the stripped copper core part into the crimping hole of the wiring copper nose.

2. Use a terminal crimping machine to press the terminal copper nose tightly. The number of crimping should be more than two.

Step 6: Install the heat shrink tubing.

1. Select a heat shrink tubing that fits the size of the cable, with a length of about 5cm.

2. Insert the heat shrink tubing over the copper nose of the wiring, so that it fully covers the crimping hole of the copper nose of the wiring.

3. Use a hot air blower to tighten the heat shrink tubing.

Step 7: Connect the "Battery-Input +" terminal of the SMC200 to the positive terminal of the Battery assembly with a cable.

1. Select bolts that match the copper nose of the wiring.

2. Firmly attach the copper noses at both ends of the connection to the "battery-input +" terminal of the SMC200 and the positive terminal of the Battery assembly respectively.

3. Tighten the bolts with a screwdriver or wrench.

Step 8: Connect the "Battery-input-" end of the SMC200 to the negative terminal of the Battery assembly with a cable as done in step 7.

Step 9: Connect the "PV-input +" terminal of the SMC200 to the positive terminal of the photovoltaic module using a cable as in Step 7.

Step 10: Connect the "PV-input -" terminal of the SMC200 to the negative terminal of the photovoltaic module using a cable as in Step 7.

Step 11: Confirm that the wiring is secure.

5.4.3 Grounding wiring

For safety purposes, all SMCS need to be grounded through PE conductors. The PE copper bars inside the SMC200 cabinet are already reliably connected to the SMC200 enclosure inside the cabinet. When making the PE connection, the PE grounding copper bars need to be reliably connected to the equipotential bonding device at the installation site or in the electrical control room. The diameter of the grounding cable shall not be less than half of the diameter of the AC output cable, and the grounding resistance shall not be higher than 4Ω.

The connection inlet and outlet should be placed at the bottom of the SMC200. After all the connections are completed, the connection inlet and outlet must be sealed with fireproof mud to prevent dust and small animals from entering the SMC200 interior.



Connect a few connection wires to the PE stud. This is for individual components inside the SMC200 that need to be grounded. Do not make any changes privately to avoid the danger of electric shock!

5.5 Communication

The ATESS SMC200 series uses multiple communication methods.

● RS485. Monitoring plus communication

1. The energy storage controllers communicate with each other via RS485 lines, and finally connect to our company's "Enerlog" and upload to the server via the network, which can remotely monitor the operation status of a single/multiple energy storage controllers in real time. RS485 communication line is made with terminal blocks at both ends, and the terminal blocks at both ends are connected in parallel to make the RS485 communication line. The true length should not exceed 1000 meters. To ensure transmission quality, please use a dedicated twisted-pair shielded communication line. The 485 interface of the energy storage controller is located on the control board inside the machine. Please distinguish between "A" and "B".

2. If Enerlog is not used for monitoring, the user's own monitoring device needs to be compatible with ATESS's 485 communication protocol.

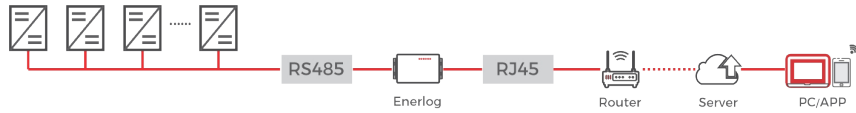

● SMC200-CAN communication

1. When the energy storage controller is used with the SMC200, it needs to communicate with the SMC200, the battery is shared, and the PCS and SMC200 communicate with the SMC200's CAN through the PCS' CANB port.

2. SMC200 and energy storage controller series The communication interface of the energy storage controller is in the same position, please distinguish between "L" and "H", incorrect connection will result in inability to communicate normally.

3. Both ends of the CAN communication line are made with terminal blocks, and the terminal blocks at both ends are connected in parallel to make the CAN communication line. It is recommended to use a dedicated shielded communication line to reduce communication interference and improve the stability of system operation

4. If the user does not use a BMS battery system produced by ATESS, the user's own BMS battery system needs to be compatible with ATESS' BMS communication protocol.

● Parallel communication

When used in parallel, connect the CAN interfaces of multiple SMCS using twisted-pair shielded wires.

The parallel function is a special feature. Please enable this function under the guidance of a technician from ATESS.

5.6 Single-parallel system wiring with CAN communication wiring

5.6.1 Single-machine system wiring

The following is the wiring diagram of a single SMC200 with a PCS energy storage machine:

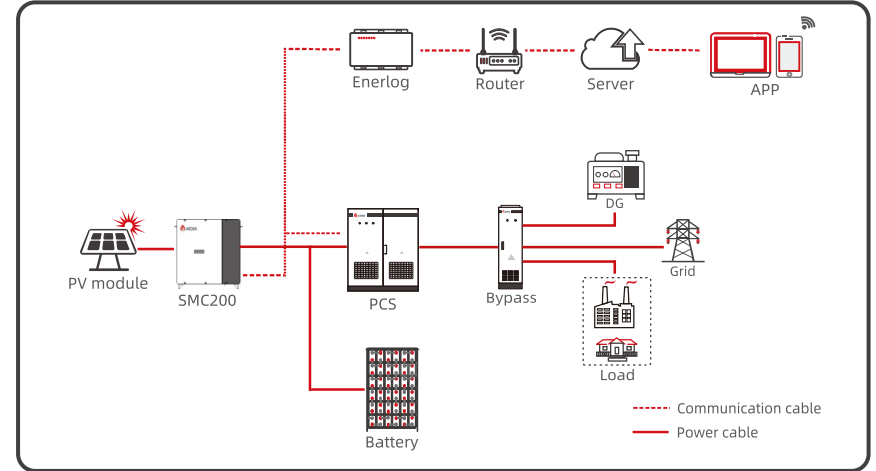

5.6.2 Parallel-machine system wiring and CAN communication wiring

The following lists the wiring diagram of a system where 4 SMC200 units are connected in parallel and 2 PCS units are connected in parallel. The output terminals of multiple SMC200 units are connected together and then connected to the battery terminal of the PCS.

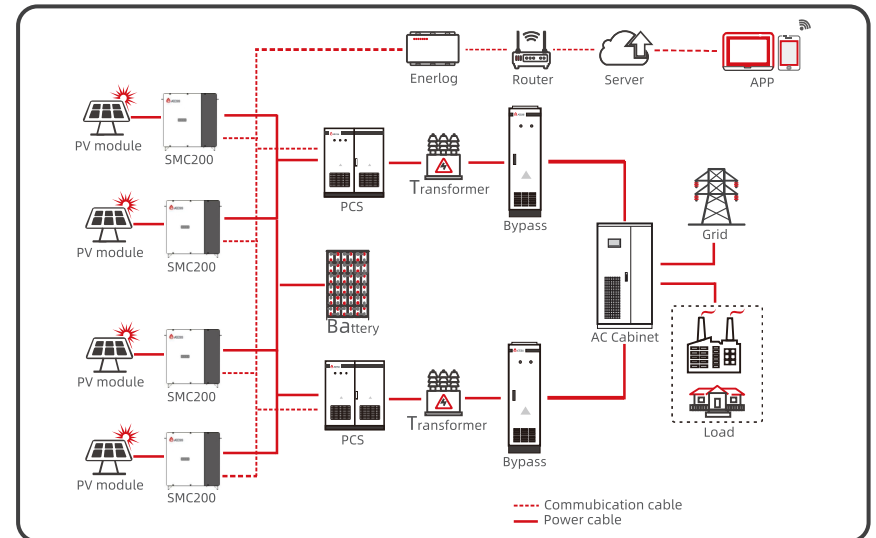

Initial Power On 6

The following figure shows the wiring diagram of CAN communication between the above system, which includes the connection mode and port of CAN communication when multiple SMCS are connected in parallel. If there is only one or more SMC200, the CAN connection port remains the same, and the port connected to the PCS remains the same.

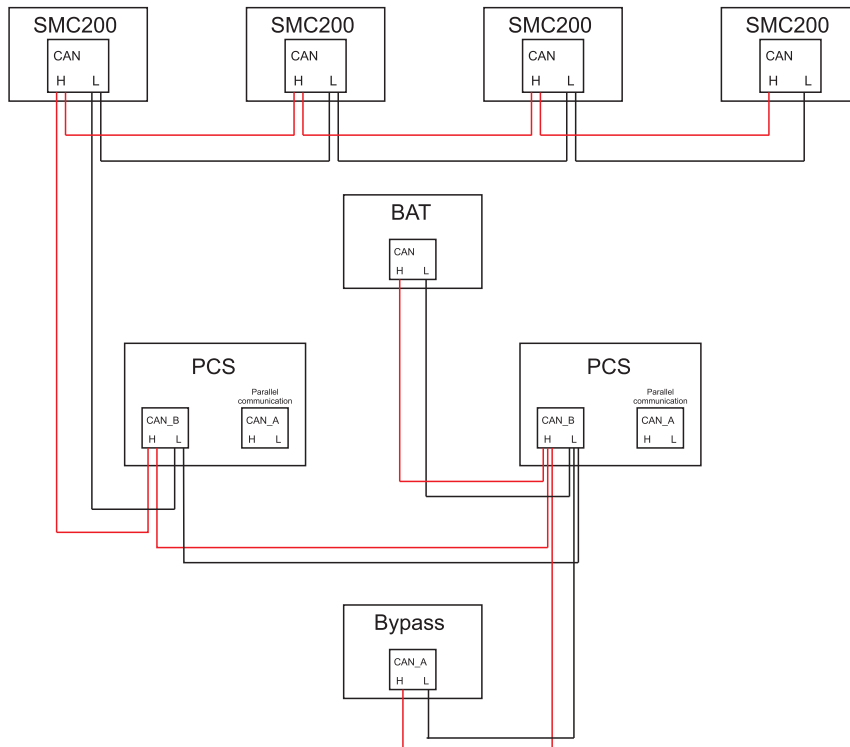

6.1 Pre-operation Inspection

Before the SMC200 is put into operation, its installation should be inspected. At least two staff members should pay attention to the inspection according to the items listed in the table below to ensure the correctness of each installation.

Mechanical installation item inspection

- SMC200 shows no deformation or damage
- SMC200 has a stable and reliable back fixation and support
- There is enough space around SMC200
- The temperature, humidity and ventilation conditions of the environment where SMC200 is located meet the requirements
- The cooling air circulates smoothly
- The cabinet body has complete and reliable sealing protection

Electrical installation inspection

- SMC200 grounding is complete and firm
- The PV voltage matches the rated output voltage of the SMC200
- The positive and negative poles of the DC input and output connections are correct, and the tightening torque meets the requirements
- The communication wiring is correct and should be kept at a certain distance from other cables
- The cable wire numbers are marked correctly and clearly

Other checks

- All the useless conductive parts are fastened tightly with insulating cable ties
- There are no remaining tools, parts, conductive dust or other foreign objects from drilling inside the cabinet
- There is no condensed moisture or ice inside the cabinet

6.2 Power On

SMC200 uses DC power supply.

● Battery power

Power on to use battery power, close the battery circuit breaker. After powering on, do not start up immediately. Instead, check the fault information page and see if the operation Settings are in line with the actual situation. For details, see Chapter 7.

7 Human-machine Interface

7.1 Introduction to Touch Screen

The user can view the operating information of the SMC200 and set the operating parameters of the SMC200 on the upper computer software. For ease of operation, the logic structure distribution diagram of the upper computer menu is provided below.

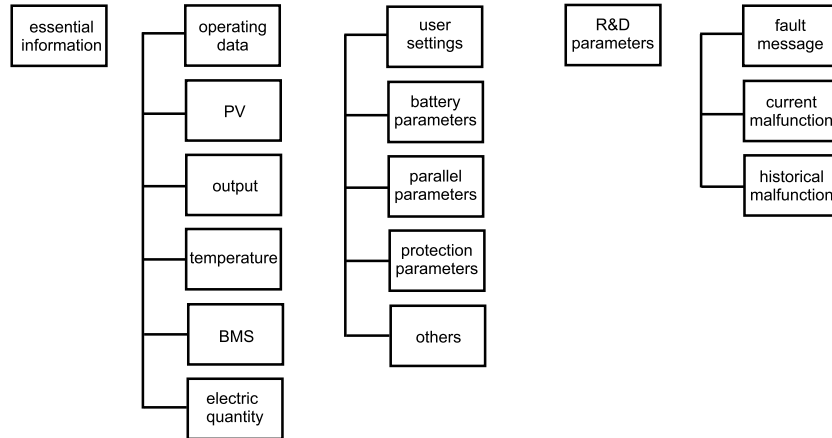

SMC200 upper computer menu logic structure distribution

After opening the host computer, enter the basic information page. After configuring the serial port, click the OPEN button to connect the machine. After a normal connection, basic information such as the machine's SN number and software version number can be read.

7.2 Upper computer operation

7.2.1 Device connection

Click the "COM SET" button to configure the serial port. After Setting it up as shown below,click "Setting". Finally click OPEN to connect the device.

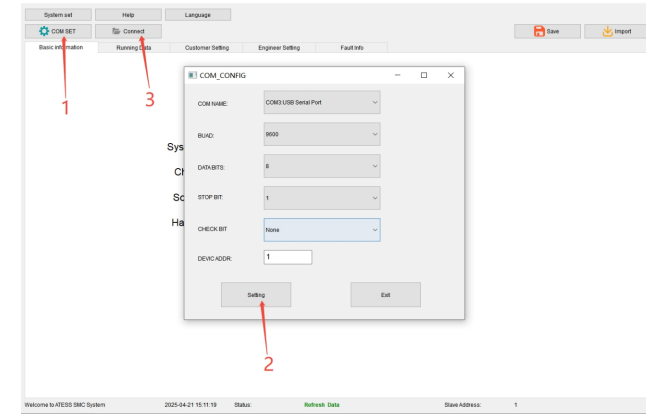

7.2.2 Basic Information page

Click the [Basic information] button above any other interface to access this page. This page mainly contains information such as the device's operating status, serial number, detection time system recognition mark, software version, hardware version, etc. Use the [ON] / [OFF] function keys at the bottom of the host computer to choose to turn on or off the device.

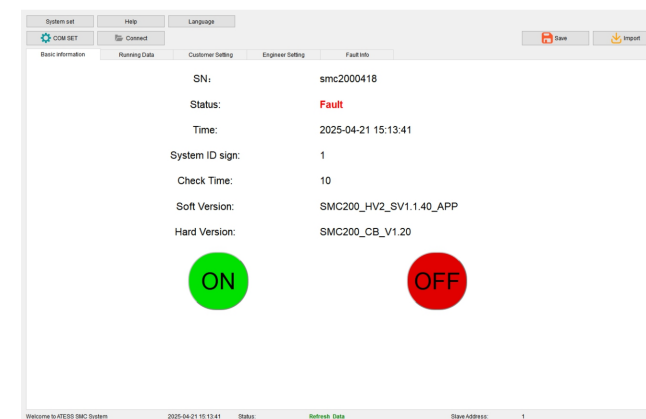

7.2.3 Run data

Click the "Running Data" button at the bottom of any other interface to enter the "Running Data" sub-menu.

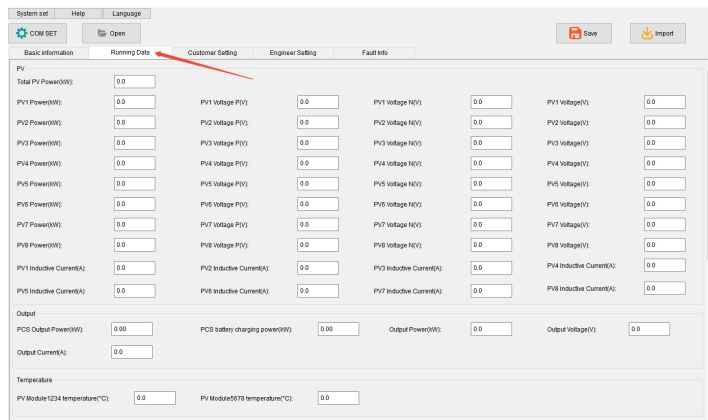

The sub-menus are: PV, Output, Temperature, BMS, Electricity.

PV: Displays current energy storage power generation parameters and real-time data including PV voltage and current, PV power, etc. (updated in real time).

Output: Displays current output parameters and real-time data including output voltage, output current, and output power, etc. (updated in real time).

Temperature: Display current PV module temperature information (updated in real time).

BMS: Displays the current cell voltage of the battery.

Electricity: Displays parameters related to power generation, including photovoltaic power generation statistics.

7.2.4 Customer Settings

Click the [Customer Setting] button on any other interface to enter the "System Settings" sub-menu.

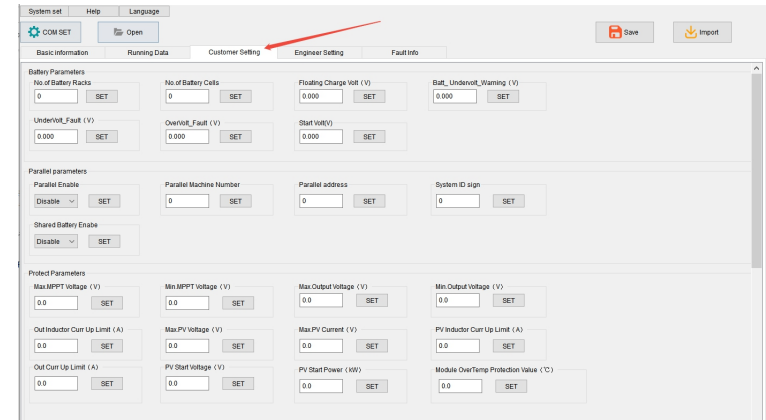

The sub-menu includes: battery parameters, parallel parameters, protection parameters, and other parameters.

1. Battery parameters:

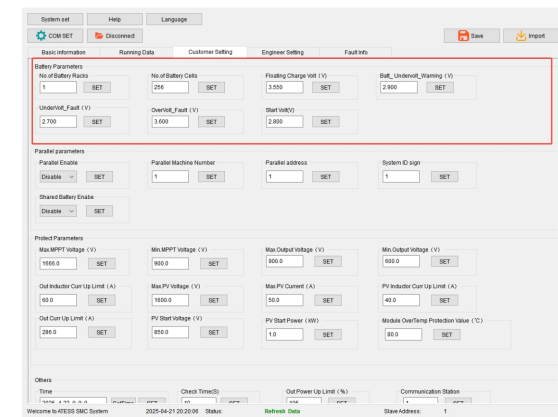

This page is for setting the battery parameters of the machine. Before leaving the factory, this page will be set in accordance with the technical agreement. The battery is an important component of the energy storage control system. The battery parameters need to be carefully confirmed to see if they are consistent with the actual situation. (If they are different from the battery parameters, contact a professional for setting.)

Number of battery packs: The number of battery components connected in parallel. For example, 2V/200Ah, 240 in series and 2 in parallel, the number of packs is 2.

Number of battery cells: The number of batteries in each string of the battery assembly. For example, 2V/200Ah, 240 series 2 parallel, the cell count is 240.

Float voltage setting: The voltage value of the battery's float cell. When the cell voltage reaches this setting, the SMC200 output power approaches zero.

Battery undervoltage alert: The cell voltage value at which the battery undervoltage alert occurs. When the battery cell voltage reaches the undervoltage alert point, the SMC200 gives an undervoltage alert.

Battery undervoltage protection: The cell voltage value during battery undervoltage protection. When the battery voltage reaches this set value, the SMC200 will protect and shut down.

Battery overvoltage protection: The overvoltage unit voltage value of the battery. When the battery voltage reaches this set value, the SMC200 will protect and shut down.

Battery start voltage: The SMC200 can start only when the voltage of the SMC200 cell is higher than the start voltage.

Shared battery enable: Shared battery, enable set 1, PCS and SMC200 communicate with SMC200's CANB through PCS 'CANB port ; Battery split, enable set 0, PCS and SMC200 communicate with SMC200's CANA through PCS 'CANA port .

BMS communication enable: Set to 1 when the battery is communicating with the BMS; Otherwise, set to 0.

2.Parallel parameters:

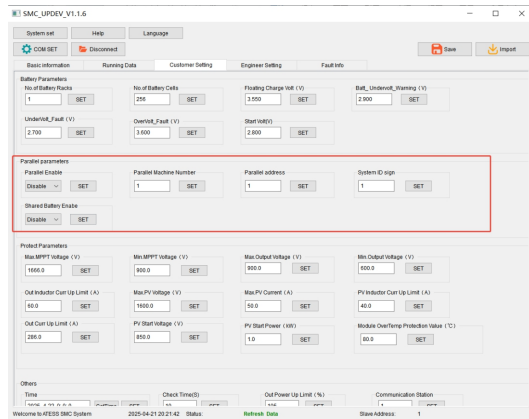

This page sets the parallel parameters for the machine. These parameters are set when the machine leaves the factory. If you need to change them, you should confirm with a professional before making any changes.

Parallel enable: When set to 1, it means the parallel function is enabled, and all devices involved in the parallel should be set to 1.

SMC200 parallel number setting: The total number of SMC200 devices in the system, set 2 for 2 devices and 3 for 3 devices.

Parallel address: It is the parallel address at which PCS receives SMC200 data. No duplicates. The address must be set from 1 and must be consecutive.

System identification tag: Background monitoring distinguishes whether devices are part of the same system and uses this to count data. Devices on the same system set the same non-zero number here.

3.Protection parameters:

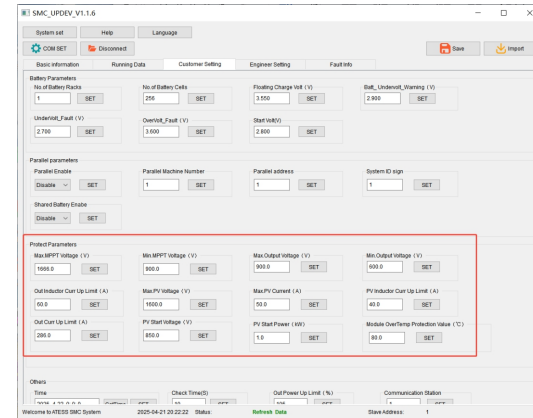

This page sets the protection parameters for the machine. These parameters are set when the machine leaves the factory. If you need to change them, you should confirm with a professional before making any changes.

MPPT voltage upper and lower limits: The selection range of photovoltaic voltage, the maximum open-circuit voltage of the PV configuration should be less than the upper limit value, when the PV voltage is less than the lower limit value, the PV output will stop, and the PV panels need to be reasonably configured.

Output voltage upper and lower limits: If the output voltage is above the upper limit or below the lower limit, a fault will be reported and operation will be stopped.

Upper limit of output inductor current, upper limit of output current: If the current exceeds the set value, the corresponding fault information will be reported and the machine will stop running.

PV voltage limit: When PV voltage is higher than this set value, the machine will report a PV overvoltage fault and the machine cannot operate.

PV current limit: The SMC200 is set to 55(instantaneous), and when the PV current exceeds the set value,a PV overcurrent fault is reported and the machine stops running.

The upper limit of PV inductor current: SMC200 is set to 40 (effective). If the PV inductor current exceeds the set value, a PV inductor overcurrent fault (INT) will be reported and the machine will stop running.

PV start voltage: The minimum voltage value for MPPT to track.

PV start power: PV is less than that power and the MPPT is restarted for tracking.

Module over-temperature protection value: If the module temperature is higher than this set value, the machine will report a PV module over-temperature fault and stop running.

4.Other parameters:

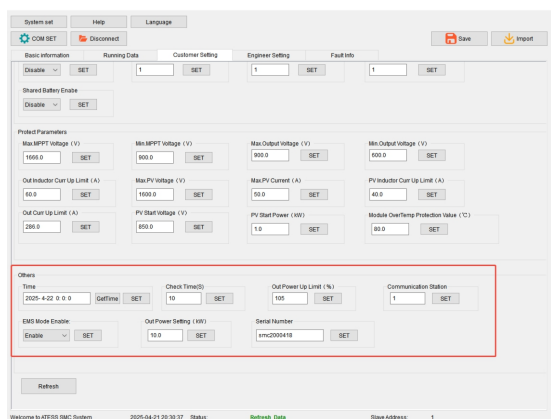

This page sets other parameters of the machine, which are set when the machine leaves the factory and need to be changed with the confirmation of a professional.

Time setting: When the machine is turned on, the time needs to be checked. This time determines whether the soft start of the machine is successful. After checking the time, the contactor is engaged, the startup is successful, and it enters the normal working state.

Check the time: When the machine is turned on, it is necessary to check the time. This time determines whether the machine has a successful soft start. After the check time ends, the contactor is engaged, the machine is turned on successfully, and it enters the normal working state.

Upper limit of output power: reserved.

485 communication station number setting: Modify the 485 address when RS485 communication is needed.

EMS mode enabled: When enabled, stop the mppt calculation, and the SMC200 runs in EMS mode with a fixed power output

Output power setting: After EMS enable is enabled, the SMC200 runs EMS mode and the power output by the SMC200.

Serial number: Device serial number, usually recorded on the machine nameplate.

Power reset enable: Power statistics reset.

7.2.5 Development Setting

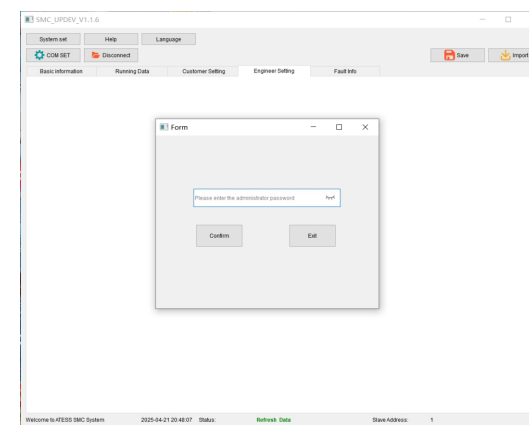

This page is the hidden protection parameter Settings page. Data is an important part of SMC200 control and is factory preset parameter. Do not modify it without the consent of ATESS personnel.



The page without instructions is factory preset parameter, please do not modify. If the subsequent scheme changes, please modify the parameters under the guidance of ATESS.

7.2.6 Historical data

Click the [Fault Info] button at the bottom of any other interface to enter the "Historical Data" sub-menu.

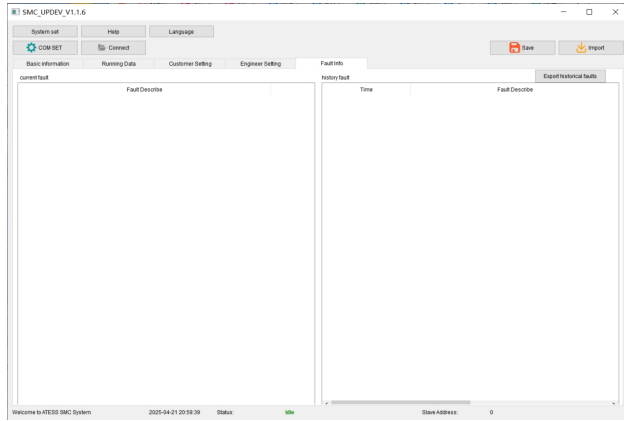

Common historical faults: Swipe up and down the progress bar to view details of all common historical faults. For more common faults information, see Appendix 7.3.

7.3 LCD Display Information Schedule

Fault Information Record

No	Information	
	English	Chinese
1	PV_Inverse_Failure	Pv接反永久故障
2	EEPROM_Write_Failure	EEPROM写永久故障
3	EEPROM_Read_Failure	EEPROM读永久故障
4	BAT_Reversed_Failure	电池反接故障
5	PV1_VoltHigh_Fault	PV1过压（有效值）故障
6	PV2_VoltHigh_Fault	PV2过压（有效值）故障
7	PV3_VoltHigh_Fault	PV3过压（有效值）故障
8	PV4_VoltHigh_Fault	PV4过压（有效值）故障
9	Batt_OverVolt_Fault	电池单体电压过压故障
10	OUT_OverVolt_Fault	输出（有效值）过压故障
11	OUT_OverCurr_Fault	输出（有效值）过流故障
12	PV_L1_BuckOverCurr_Fault	PV1过流（有效值）故障
13	PV_L2_BuckOverCurr_Fault	PV2过流（有效值）故障
14	INT_PV_L1_OverCurr_Fault	PV1过流（瞬时值）故障
15	INT_PV_L2_OverCurr_Fault	PV2过流（瞬时值）故障
16	INT_PV1_OverVolt_Fault	Pv1过压（瞬时值）故障

No	Information	
	English	Chinese
17	INT_PV2_OverVolt_Fault	Pv2过压（瞬时值）故障
18	INT_Out_OverVolt_Fault	输出电压（瞬时值）故障
19	PV_Module1_OverTemp_Fault	PV模块1过温故障
20	INT_OUT_OverCurr_Fault	输出过流（瞬时值）故障
21	INT_PV_L3_OverCurr_Fault	PV3过流（瞬时值）故障
22	INT_PV_L4_OverCurr_Fault	PV4过流（瞬时值）故障
23	INT_PV_L5_OverCurr_Fault	PV5过流（瞬时值）故障
24	PV1_P_OverVolt_Fault	PV1正半边过压故障
25	PV2_P_OverVolt_Fault	PV2正半边过压故障
26	PV3_P_OverVolt_Fault	PV3正半边过压故障
27	PV4_P_OverVolt_Fault	PV4正半边过压故障
28	PV5_P_OverVolt_Fault	PV5正半边过压故障
29	PV6_P_OverVolt_Fault	PV6正半边过压故障
30	PV7_P_OverVolt_FaultP	PV7正半边过压故障
31	PV8_P_OverVolt_Fault	PV8正半边过压故障
32	PV_Module2_OverTemp_Fault	PV模块2过温故障
33	DC_SoftStart_Fault	电池软启故障
34	PV_L1_OCP_Fault	PV1_OCP故障
35	PV_L2_OCP_Fault	PV2_OCP故障
36	LowTemp_Fault	低温故障
37	PV_L3_OCP_Fault	PV3_OCP故障
38	PV_L4_OCP_Fault	PV4_OCP故障
39	PV_L5_OCP_Fault	PV5_OCP故障
40	LcdEmergencyStop	LCD关机
41	PV_L6_OCP_Fault	PV6_OCP故障
42	PV_L7_OCP_Fault	PV7_OCP故障
43	PV_L8_OCP_Fault	PV8_OCP故障
44	Thunder1_Fault	直流1防雷器故障
45	Thunder2_Fault	直流2防雷器故障
46	Fault_Feedback_Warning	故障反馈告警

No	Information	
	English	Chinese
47	Fan_1_Fault_Warning	风扇1故障告警
48	Fan_2_Fault_Warning	风扇2故障告警
49	Fan_3_Fault_Warning	风扇3故障告警
50	Temp_Derating_Warning	过温减载告警
51	Batt_UnderVolt_Warning	电池欠压告警
52	PCS_Communication_Warning	PCS通信告警
53	Batt_UnderVolt_Protection_Warning	电池低压告警
54	Fan_4_Fault_Warning	风扇4故障告警
55	Fan_5_Fault_Warning	风扇5故障告警
56	Fan_6_Fault_Warning	风扇6故障告警
57	PV_L5_OverCurr_Fault	PV5 (有效值) 过流故障
58	INT_PV3_OverVolt_Fault	PV3过压 (瞬时值) 故障
59	INT_PV4_OverVolt_Fault	PV4过压 (瞬时值) 故障
60	INT_PV5_OverVolt_Fault	PV5过压 (瞬时值) 故障
61	PV5_VoltHigh_Fault	PV5电压 (有效值) 高故障
62	PV_L3_OverCurr_Fault	PV3 (有效值) 过流故障
63	PV_L4_OverCurr_Fault	PV4 (有效值) 过流故障
64	PV1_N_OverVolt_Fault	PV1负半边过压故障
65	PV2_N_OverVolt_Fault	PV2负半边过压故障
66	PV3_N_OverVolt_Fault	PV3负半边过压故障
67	PV4_N_OverVolt_Fault	PV4负半边过压故障
68	PV5_N_OverVolt_Fault	PV5负半边过压故障
69	PV6_N_OverVolt_Fault	PV6负半边过压故障
70	PV7_N_OverVolt_Fault	PV7负半边过压故障
71	PV8_N_OverVolt_Fault	PV8负半边过压故障
72	PV_L6_OverCurr_Fault	PV6过流 (有效值) 故障
73	PV_L7_OverCurr_Fault	PV7过流 (有效值) 故障
74	PV_L8_OverCurr_Fault	PV8过流 (有效值) 故障
75	INT_PV_L6_OverCurr_Fault	PV6过流 (瞬时值) 故障
76	INT_PV_L7_OverCurr_Fault	Pv7过流 (瞬时值) 故障

No	Information	
	English	Chinese
77	INT_PV_L8_OverCurr_Fault	Pv8过流 (瞬时值) 故障
78	PV6_VoltHigh_Fault	PV6电压 (有效值) 高故障
79	PV7_VoltHigh_Fault	PV7电压 (有效值) 高故障
80	INT_PV6_OverVolt_Fault	PV6 (瞬时值) 过压
81	INT_PV7_OverVolt_Fault	PV7 (瞬时值) 过压
82	INT_PV8_OverVolt_Fault	PV8 (瞬时值) 过压
83	PV8_VoltHigh_Fault	PV8电压 (有效值) 高故障
84	INT_PV1_VoltUnbalance_Warning	PV1电压 (有效值) 不平衡告警
85	INT_PV2_VoltUnbalance_Warning	PV2电压 (有效值) 不平衡告警
86	INT_PV3_VoltUnbalance_Warning	PV3电压 (有效值) 不平衡告警
87	INT_PV4_VoltUnbalance_Warning	PV4电压 (有效值) 不平衡告警
88	INT_PV5_VoltUnbalance_Warning	PV5电压 (有效值) 不平衡告警
89	INT_PV6_VoltUnbalance_Warning	PV6电压 (有效值) 不平衡告警
90	INT_PV7_VoltUnbalance_Warning	PV7电压 (有效值) 不平衡告警
91	INT_PV8_VoltUnbalance_Warning	PV8电压 (有效值) 不平衡告警

7.3.1 Methods and steps for handling faults

The following are the troubleshooting steps:

1. Look at the screen fault record information.
2. Observe whether the running data on the screen shows any abnormalities.
3. If the running data shows normal, try restarting the screen. Check if the machine can restart. If the machine can restart, it means the fault has been eliminated. If the running data shows abnormal, see if there is a way to measure the actual values and then contact a professional.
4. If Step 3 fails to reboot, you can power the machine back on and then reboot it again.
5. If it cannot be restarted again, it means the fault cannot be eliminated automatically and you need to contact a professional.

Note: When the machine malfunctions, the customer needs to keep a clear record of the working conditions of the machine at that time, such as whether the machine is connected to the grid or off the grid, the load capacity, etc. This makes it easier to troubleshoot problems; if the machine has a serious malfunction, such as a circuit breaker tripping, contact a professional and do not restart it.

8 Operation

8.1 Startup and operation steps

After installation and system setup checks are completed, start up and run.

● First run

The first run operation steps are as follows:

1. Close SMC200_PV, battery, Output, and power supply micro-disconnect switch.
2. Check whether the screen sampling data is abnormal and consistent with the actual situation;
3. After confirming that there are no errors, turn the knob switch to "ON", click "Power on" on the LCD "Power On" page, and wait for the machine to enter "running mode";
4. While running, observe whether the data displayed on the screen is normal, whether there is a fault message, and whether the machine has any abnormal noise or odor. If any abnormal situation occurs, stop the machine immediately for inspection.



Warnings!

When checking, power will need to be turned off to ensure the machine is not powered, please be careful.

Manual shutdown

While working, you can click the power OFF button on the LCD or simply turn the knob switch to "OFF" to stop the SMC200.



Warnings!

1. After manually turning off the LCD by tapping the power button, you must manually turn ON the LCD by pressing the power button (ON); To turn OFF by turning the knob switch to "OFF", first turn the SMC200 knob switch to "ON", and then click the "Power On" button on the LCD "Power On" page to turn on, otherwise the SMC200 will not turn on automatically.
2. After manual shutdown, the SMC200 will still be powered on.

8.2 Complete the trial run

After the SMC200 runs, the following test steps are carried out:

Step 1: Check the SMC200 for any abnormalities such as excessive noise, excessive heat generation, unusual odors or smoke;

Step 2: Measure whether the output voltage and current of the SMC200 are stable;

Step 3: Operate the LCD to check if its working display is normal and accurate;

Step 4: Test if it fits the preset operating logic.

At this point, the trial operation process of SMC200 has been fully completed and it can now enter the daily operation and maintenance process.

8.3 Shutdown and power-off steps



Warnings!

After the SMC200 is completely powered off, the SMC200 remains live. If you need to operate, be sure to completely disconnect all external connections and wait for at least 5 minutes.

1. Turn the knob switch to "OFF" to turn off the power.
2. Disconnect the DC main input switch PV input and Battery input;
3. Disconnect the output switch output



Warnings!

It is normal for the SMC200 to give an alert during the power-off process and proceed with the power-off step.

9 Product Maintenance

9.1 Routine Maintenance

9.1.1 Maintenance and repair



All maintenance and repair operations on the SMC200 may only be carried out when the SMC200 is safely disconnected from the photovoltaic modules, battery modules, and grid, and when it is confirmed that these power sources will not be reconnected and at least 5 minutes or more have been waited.

Such operations can only be carried out by professional technicians who are familiar with system operations.

- **Disconnect the circuit breaker**

Operate the PV input and Battery input DC switches to disconnect the SMC200 from the photovoltaic module and the battery module, and operate the output switch to disconnect the SMC200 from the outside. Make sure the SMC200 is not accidentally reconnected. Test with a multimeter to ensure that the device is disconnected and there is no voltage. Even if the SMC200 is disconnected from the main power supply and the battery and photovoltaic module, some components inside the SMC200 (such as capacitors) still have residual voltage and discharge slowly. Therefore, after the circuit breaker is disconnected, please wait at least 5 minutes and use a multimeter to measure and confirm safety before proceeding.

- **Maintenance and modification**

Only authorized personnel of Times Energy Technology are allowed to maintain and modify SMCS. For personal safety, please use only original factory parts provided by the manufacturer. If non-original parts are used, there will be no guarantee of compliance with relevant certification criteria in terms of electrical safety, EMC, etc.

- **Functions and safety parameters**

Do not change the parameters of the SMC200 without authorization from the local power supply company and without instructions from Times Energy Technology. Changing the functional safety parameters without authorization may cause injury or damage to a person or the SMC200. In such cases, Times Energy will not provide warranty services.



Attention!
After power-off, wait for 5 minutes to confirm safety before proceeding with the repair work.
Use a multimeter to measure and ensure safety before proceeding with disassembly and assembly.

9.1.2 Replacing the air filter

During the use of the SMC200, the top dust should be cleaned regularly, and the dust screen at the air inlet should be cleaned or replaced. During the replacement of the dust screen, the SMC200 needs to be powered off.

Dust screen replacement method: The dust filter cotton on the door panel can be pulled out directly upwards for cleaning and replacement.



In order to ensure the normal operation of SMC200, the air filter needs to be cleaned regularly.

9.1.3 Perform regular maintenance

SMC200 must undergo regular maintenance work to ensure its normal operation and service life. The recommended routine maintenance cycles and tasks are shown in Table 7-2.

Maintenance Items	Cycles
Read the data from the data collector	Monthly
Clean the power module radiator	Monthly
Check the inside of the cabinet for dust, moisture, or condensation	Monthly
Check for loose cable connections and tighten screws if necessary	Monthly
Check warning labels and add or replace them promptly if necessary	Monthly
Manually inspect AC/DC circuit breakers	Monthly
Check the emergency stop button as well as the stop function of the LCD	Monthly
Check the machine for abnormal noises during operation	Weekly
Check the battery assembly for abnormalities, bulges, and smoke	Daily

Table 7-2 Routine maintenance tasks of periodic machines



All maintenance operations must be carried out on the DC side of the SMC200 with all the corresponding switches of the battery assembly open.
After the SMC200 DC switch is disconnected, some components on the SMC200 still have residual voltage. Please wait at least 5 minutes before performing maintenance operations on the SMC200.

9.2 Waste Disposal

SMC200 does not cause pollution to the environment. The materials and components of the product meet environmental protection requirements. Times Energy Technology, in accordance with environmental protection requirements, users should handle the SMC200 in accordance with local relevant regulations at the end of its service life.

10 Appendix

10.1 Product Specifications

SMC200 has no battery itself, and the output is connected to the PCS DC side or battery;

Specification parameters	SMC200
Maximum PV power (KW)	200
MPPT Voltage range (V)	900-1300
Maximum input current (A)	160 (20*8)
MPPT quantity	8
Rated PV power	180kW

Note: When configuring the photovoltaic and battery of the SMC200, pay attention to the voltage range of the rear stage to avoid burning out the controller.

10.2 ATESS Factory Warranty

●Warranty period

The warranty period of SMC200 is one year. If otherwise specified in the contract, the contract shall prevail.

During the warranty period, the customer shall show the invoice and date of purchase to the service personnel of ATESS. At the same time, the nameplate mark on the product shall be clear and visible, otherwise, ATESS has the right not to provide warranty service.

●Warranty conditions

In the event of failure during the warranty period, ATESS will repair or replace the product free of charge; The customer shall Set aside some time to repair the faulty machine.

●Liability exemption

In case of the following circumstances, ATESS has the right not to conduct warranty:

1. Products without logo of ATESS Power Technology logo.
2. The product or component that has exceeded the valid warranty period of ATESS.
3. Failure or damage(such as high temperature, low temperature, too wet or dry, high altitude, unstable voltage or current, etc.) caused by working in beyond-specified environment or wrong installation, storage or use that violates the instructions.
4. Failure or damage caused by unauthorized installation, repair, modification or disassembly, except for those authorized by ATESS.
5. Failure or damage caused by using components that not supplied by ATESS.
6. Failure, damage or transportation damage caused by accident or human factors (operation error, scratching, carrying, bumping, improper voltage connection etc.).
7. Failure or damage caused by force majeure (such as earthquake, lightning, fire etc.).
8. Failures or damages caused by other factors rather than quality problems of the supplied product itself(including components).