



# ATESS Enerstack100

User Manual

# Contents

<b>1.Introduction</b> .....	<b>01-02</b>
1.1 Contents	
1.2 Applicable Personnel	
1.3 Signs	
<b>2.Safety</b> .....	<b>03-03</b>
2.1 Notice for Use	
2.2 Proper Installation	
<b>3.Battery Description</b> .....	<b>04-05</b>
3.1 Brief Introduction	
3.2 Product Properties	
3.3 Product Identity Definition	
<b>4.Product Specifications</b> .....	<b>06-26</b>
4.1System Performance Parameter	
4.2Battey Module	
4.3Environmental Requirements	
4.4Installation location precautions	
4.5Unpacking inspection	
4.6Equipment installation	
4.7 Battery Capacity Description	
<b>5.Maintenance</b> .....	<b>27-30</b>
5.1Troubleshooting	
5.2Replacement of Main Components	
5.3Battery Maintenance	
<b>6.Storage</b> .....	<b>30</b>
<b>7.Shipment</b> .....	<b>31</b>
<b>Contact</b> .....	<b>32</b>

# 1 Introduction

## 1.1 Contents

This manual provides comprehensive product information and installation instructions for users of ATESS Enerstack100 series batteries manufactured by Shenzhen ATESS Power Technology Co., Ltd. (hereinafter referred to as ATESS).

Prior to using the product, please carefully review this manual and ensure it is readily accessible to installation, operation, and maintenance personnel.

ATESS will not notify users of any updates or revisions made to this manual. The content of the manual will be continuously updated and amended; therefore, slight discrepancies or errors with the actual product may occur. For the latest version of this manual, please refer to the actual product, contact your local distributor, or visit our website at [www.atesspower.com](http://www.atesspower.com).

## 1.2 Applicable Personnel







The applicable personnel must meet the following requirements:

- Battery installation should be carried out by professional electrical personnel certified by relevant departments.
- Operators should have a thorough understanding of the composition and working principle of the batteries.
- It is essential for operators to carefully read this manual.
- The operator should familiarize themselves with the relevant standards of the country/region where the project is located.

In case any issues arise during the installation process, installers can contact ATESS.

## 1.3 Sign

To ensure the safety of personal and property during installation or efficient use of this product, relevant information is provided in the manual along with appropriate symbols for emphasis. The following list outlines potential symbols used in this manual; please review them carefully to optimize your usage.

 <b>Danger</b>	<p>This sign indicates a high potential hazard if not performed correctly as required, which could result in death or serious injury.</p>
 <b>Attention</b>	<p>This sign indicates a situation in which failure to comply with the required performance standards may result in equipment malfunction and property damage under specific conditions.</p>
	<p><b>Caution! Electric Shock Hazard</b></p> <p>The device contains AC and DC power terminals. Disconnect each power supply separately and wait for at least five minutes to ensure complete discharge of the rectifier controller.</p>
	<p><b>Caution! Fire Hazard</b></p> <p>The installation of this product is only suitable for concrete or other non-combustible materials. It is imperative to keep a safe distance from any flammable and explosive substances.</p>
	<p><b>PE Terminal</b></p> <p>The PE Terminal is used for protection and requires a secure grounding connection to ensure the safety of personnel.</p>
	<p><b>Electric Shock Hazard</b></p> <p>If there is a risk of electric shock from the capacitor, disconnect all power supplies and wait 5 minutes before removing the cover.</p>

## 2 Safety

### 2.1 Notice for Use

The Enerstack100 installation and service personnel must undergo training to ensure their familiarity with the general safety regulations that need to be followed while working on electrical equipment. Additionally, they should also have knowledge of local regulations and safety requirements.

- Prior to usage, it is essential to thoroughly read this manual. Failure to adhere to the instructions provided in this manual may result in damage to the equipment, for which the Company reserves the right not to provide quality assurance.
- Only qualified electrical engineers are permitted to operate the Battery system.
- During operation, refrain from touching any other electrical components except for accessing operational information through the display screen.
- In case of an emergency, switch off the breaker on the BPU for immediate power cutoff of all functions of the whole battery cluster.
- All electrical procedures must comply with local standards.

### 2.2 Proper Installation

The proper installation of the Enerstack100 entails adhering to all instructions outlined in the user manual pertaining to equipment transportation, installation, electrical connection, and operation. ATESS shall not be held liable for any damages resulting from improper utilization of the equipment.

The Enerstack100 possesses an IP65 protection progress and is specifically designed for outdoor installations.

Additionally, ensuring appropriate usage of the equipment necessitates attentiveness towards the following aspects:

- Adherence to safety instructions stated herein and below.
- Compliance with guidelines specified in the Enerstack100 user manual.
- Consideration of technical data associated with the equipment.

## 3 Battery Introduction

### 3.1 ENERSTACK Overview

ENERSTACK100 is a high-voltage battery storage system based on lithium iron phosphate batteries, and it is one of the new energy storage products developed and produced by ATESS. It can be used to support reliable power for various types of equipment and systems. ENERSTACK100 is especially suitable for application scenes of high power, limited installation space, restricted load-bearing and long cycle life.

### 3.2 Product Properties

The entire module is non-toxic, non-polluting and environmentally friendly.

Anode material is made from LiFePO<sub>4</sub> with safety performance and long cycle life.

The Battery Management System (BMS) comes with protective functions including over-discharge, over-charge, over-current and high/low temperature.

The system can automatically manage the charge and discharge state and balance the current and voltage of each cell.

Flexible configuration, multiple battery modules can be connected in series for expanding voltage and capacity.

0.5C discharge, built-in natural cooling system.

Each PACK has an independent fire extinguishing device.

The module has less self-consumption, up to 10~12 months without charging; no memory effect, excellent performance of shallow charge and discharge.

Working temperature range is from -20 to +40°C, with excellent discharge performance and cycle life.

Small size and lightweight, standard module is easy to install and maintain.

### 3.3 Product Identity Definition











ATESS							
Module	Enerstack100						
Energy code	B561	B556	B551	B546	B540	B535	B530
Module Qty	12	11	10	9	8	7	6
Rated Voltage	614.4V	563.2V	512V	460.8V	409.6V	358.4V	307.2V
Operating Voltage Range	537.6V~691.2V	492.8V~633.6V	448V~576V	403.2V~518.4V	358.4V~460.8V	313.6V~403.2V	268.8V~345.6V
Rated Capacity	100Ah						
Rated Energy	61.44 KWh	56.32 KWh	51.2 KWh	46.08 KWh	40.96 KWh	35.84 KWh	30.72 KWh
Ingress Protection	IP65						
Communication Port	CAN2.0B/RS485						
DATE OF MADE							
S/N	DM-940.ZT0091001						
	www.ateSSpower.com MADE IN CHINA						

Figure 3-1 Battery energy storage system nameplate

<b>LiFePO<sub>4</sub> Lithium-ion Battery</b>	
<b>Model type:</b>	ESS- BM-51.2-100CPB-S
<b>Date of manufacture:</b>	
<b>Rated capacity:</b>	100Ah
<b>Nominal voltage:</b>	51.2V
<b>Watt-hour:</b>	5120Wh
<b>Cell designation:</b>	IFpP51/162/119/[(8S)2S]M/-20+60/95
<b>Rate charge:</b>	50A(0.5C) charge to 57.6V CC-CV
<b>Rate discharge:</b>	50A(0.5C) discharge to 44.8V
<b>Beware of fire hazard! Disposal acc. to local regulations!</b>	
Shenzhen AteSS Power Technology Co., Ltd.	Made in China

Figure 3-2 Battery module label

The primary external components of the RTF consist of an LED indicator, an LCD touch screen, and an emergency stop button.

	This battery meets European directive requirements.
	After the useful life of the battery, it can continue to be used after being recycled by a professional recycling organization.
	Do not dispose of the scrapped batteries with household waste; they must be recycled by professional personnel or institutes.
	Read the user manual before use.
	Inflammable.
	Battery voltage is higher than safe voltage, direct contact with electric shock hazard.
	Do not place near open flame or incinerate.
	If catch fire, do not put out with water.
	If catch fire, do not put out with dry powder fire.
	Do not cut or spear with sharp objects.

## 4 Product specifications

### 4.1 System Performance Parameter

Energy code	BS30	BS35	BS40	BS46	BS51	BS56	BS61
Module Number	6	7	8	9	10	11	12
Weight	308	356	404	464	512	560	680
Dimension (W/H/D)mm	690*525*275	690*525*1445	690*525*1615	1680*525*1105	1680*525*1105	1680*525*1275	1680*525*1275
Normal capacity	100Ah	100Ah	100Ah	100Ah	100Ah	100Ah	100Ah
Normal Energy/kWh	30.7	35.84	40.96	46.08	51.2	56.32	61.44
Normal Voltage/V	307.2	358.4	409.6	460.8	512	563.2	614.4
Voltage Range/V	268.8~345.6	313.6~403.2	358.4~460.8	403.2~518.4	448~576	492.8~633.6	537.6~691.2
Recommended charge& discharge current	50A (0.5C)						
Depth of discharge	90%						
Cycle life	6000 cycles						
Charging temperature range	0°C~40 °C						
Discharging temperature range	-20°C~40 °C						
Communication	CAN/RS485						
Protection grade	IP65						
Fire extinguishing system	Aerosol						
Installation method	Stacked installation						
Cooling method	Smart air cooling						
Max. altitude	3000m						

Table 4-1 The parameter of the system

[1]Test conditions: 0.2C Charging/Discharging, @25°C, 95% DOD

## 4.2 Battery Module

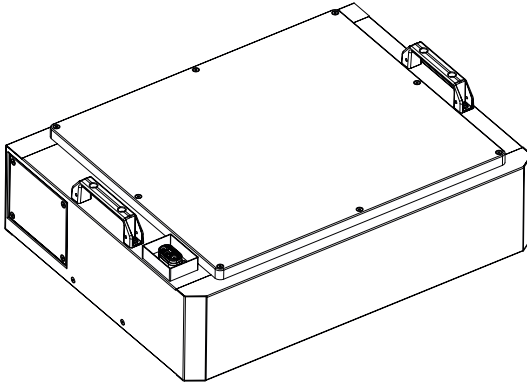

Figure 4-1 Battery Module

Model name	ESS-B-51.2-100CPB-S
Cell technology	Li-ion (LFP)
Battery module capacity (kWh)	5.12
Battery module voltage (Vd.c.)	51.2
Battery module capacity (Ah)	100
Number of battery module cells (pcs)	16
Battery cell capacity (Wh)	320
Battery cell voltage (Vd.c.)	3.2
Battery cell capacity (Ah)	100
Dimensions (W*D*H, mm)	690*525*170
Pollution degree (PD)	II
Weight (kg)	55

Table 4-2 Battery parameters

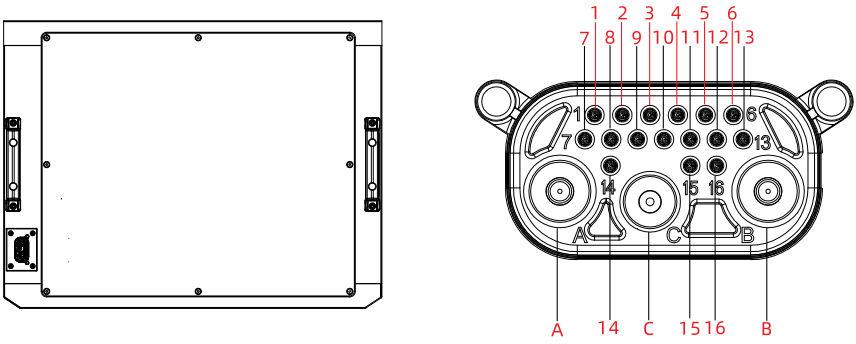

Figure 4-2 Front View of the Battery

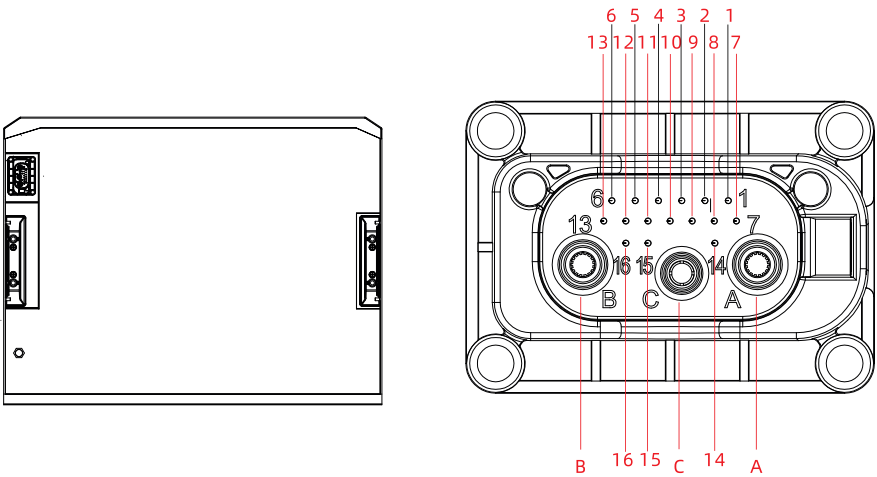

Figure 4-3 Top View of the Battery

PIN	Top Connector	Bottom Connector
1	CAN1_H	CAN1_H
2	CAN1_L	CAN1_L
3	CAN_GND	CAN_GND
4	NC	NC
5	24V-	24V-
6	24V-	24V-
7	NC	NC
8	NC	NC
9	NC	NC
10	NC	NC
11	IPC	NC
12	24V+	24V+
13	24V+	24V+
14	ADD_DI	ADD_DO
15	NC	NC
16	IMA	IMA

## Battery Controller

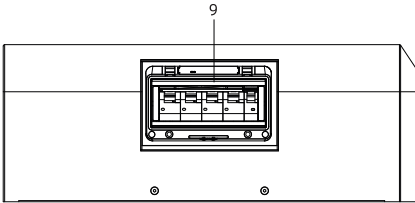

Figure 4-4 Left side interface

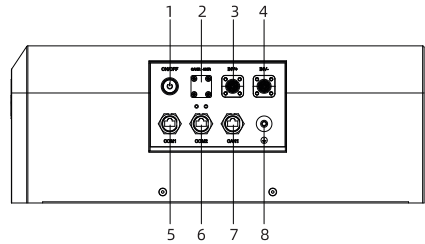

Figure 4-5 Right side interface

Item	Name	Definition
1	Dimensions(W*D*H,mm)	690*525*200
2	Weight(kg)	23.5
3	Output Voltage (Vdc)	268.8~691.2V
4	Maximum Output Current	125A

Table 4-4 BPU parameters

Item	Name	Definition
1	ON/OFF	Turn on the switch to power the BMS system.
2	DIP Switch	Set the address of BPU.
3	INV+	Connect battery system to inverter positive terminal.
4	INV-	Connect battery system to inverter negative terminal.
5	COM1	RJ45 communication port between battery system and inverter.
6	COM2	Parallel communication connection of multi cluster systems.
7	CAN1	Communication port between battery system and inverter or EMS.
8	Grounding	The BPU must be grounded.
9	Breaker	The master switch of the battery system, you must switch it on before switching on the Power on and Power WAKE switches; short circuit protection.

Table 4-5 Side interface definition

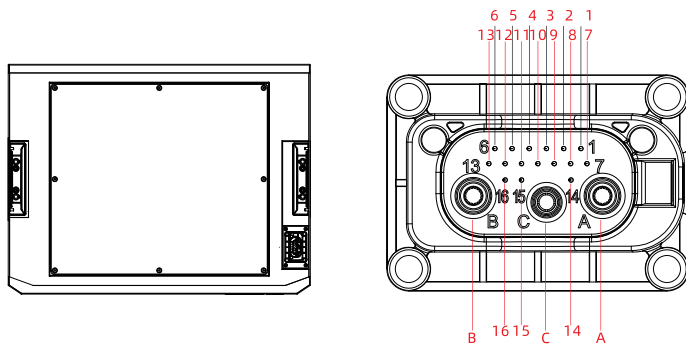

Figure 4-6 Top view of the BDU

Item	Definition	Item	Definition	Item	Definition	Item	Definition
1	CAN1_H	6	24V-	11	NC	16	NC
2	CAN1_L	7	NC	12	24V+	A	
3	CAN_GND	8	NC	13	ADD_DI	B	
4	NC	9	NC	14	NC	C	
5	24V-	10	NC	15	NC		

Table 4-6 Connector definition

**DANGER!**

DO NOT switch off the ON/OFF switch during normal operation, only in emergencies. Otherwise it will cause the battery current to surge.

**CAUTION!**

If the DC breaker trips because of over-current or short circuit, you must wait for 30 minutes to switch it on again, otherwise it may cause damage to the breaker.

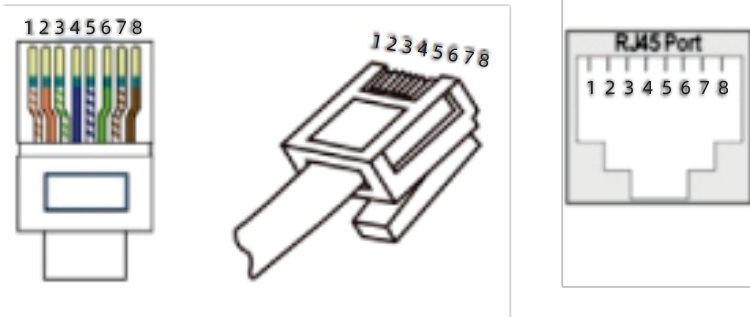

Figure 4-7 "Inverter CA/RS485" port pins Table

PIN	Color	Definition
1	NC	NC
2	NC	NC
3	Yellow	485A
4	Red	CANH
5	Black	CANL
6	Blue	485B
7	NC	NC
8	NC	NC

### 4.3 Environmental Requirements

#### **DANGER!**

##### **Cleanliness**

The battery system has high voltage connectors. The environmental conditions will affect the isolation of the system.

Before installation and switch-on, dust and swarf must be removed to keep the system clean. The environment must be dust-proof to a certain extent.

Dust and humidity must be regularly checked during continuous operation of the system.



##### **Fire Protection System**

The room must be equipped with a fire protection system or fire extinguishers (Recommended: foam extinguisher). The fire protection system needs to be regularly checked to ensure its normal condition. Please refer to your local fire protection equipment for use and maintenance requirements.

##### **Grounding System**

Make sure that the grounding point for the battery system is stable and reliable before installation. If the battery system is installed in an independent equipment cabin ( e. g. container), ensure that the grounding of the cabin is stable and reliable.

The resistance of the grounding system must be  $\leq 1\Omega$ .

#### **CAUTION!**

##### **Temperature**

Enerstack100 system working temperature range:  $-20^{\circ}\text{C}$  to  $+40^{\circ}\text{C}$ ; Optimum temperature:  $18^{\circ}\text{C}$  to  $30^{\circ}\text{C}$ ; Exceeding the working temperature range will cause over-temperature/under-temperature alarms or protection of the battery system which may lead to the reduction of cycle lives.



##### **Cooling System**

It is essential to equip a cooling system to keep the battery system in a relevant temperature range. Over- temperature/under- temperature alarms or protection of the battery system may lead to the reduction of lifespan.

### 4.4 Installation location precautions



#### **DANGER!**

Please note that the battery should be installed with a minimum safe clearance from the surrounding equipment or battery. Please refer to the minimum clearance diagram below.

## ● Installation Clearance

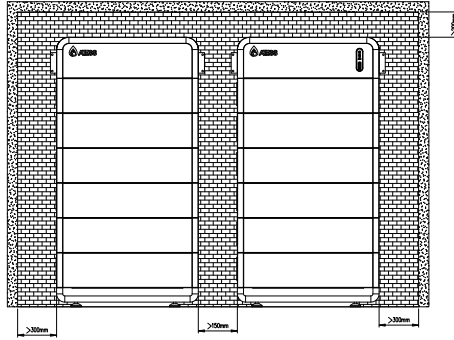

## ● Installation Location

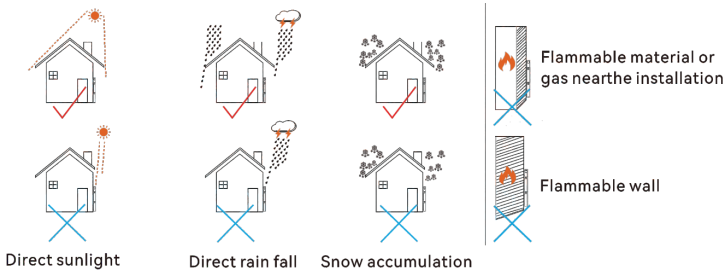
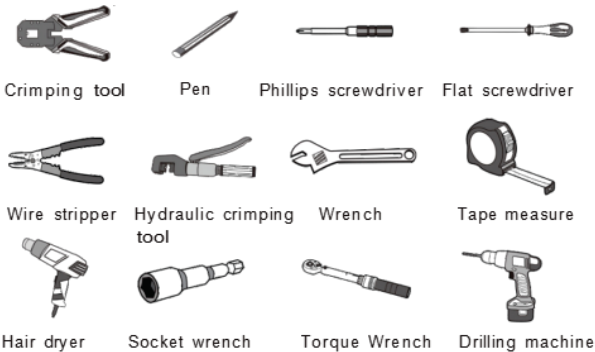

Figure 4-8 Suggested installation location

## ● Tools:

The following tools are required to install the battery pack:



## ● Safety Requirement

We recommend wearing the following safety gear when working with batteries.



Insulated gloves



Safety goggles



Safety shoes

Figure 4-9 Safety gear

### CAUTION!



1. The system should be installed with the help of at least 2 grown-up males.
2. If more than 8 of the battery to be configured, It is suggested to divide into two columns.
3. The battery system should be installed indoors, away from flammable and explosive materials.

## 4.5 Unpacking inspection

- When the equipment arrives at the installation site, unloading should be performed according to rules and regulations, to prevent from being exposed to direct sunlight. The battery should not be installed in direct sunlight. Please refer to Section 3.2.
- Before unpacking, the total number of packages shall be indicated according to the shipping list attached to each package, and all packages shall be checked for good condition.
- Handle with care and protect the surface coating of the goods.
- Upon opening the package, the installation personnel should read the technical documentation, verify the list according to configuration table and packing list and ensure that the goods are complete and intact. If the internal packing is damaged, goods should be examined and recorded in detail.











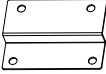

Name	Specification	Quantity	Image
<b>Package A</b>			
BPU	690*525*200	1	
Base	690*525*93	1	
Fixing bracket	To secure with the wall	2	
Expansion Bolt	M6*80	4	
Positive terminal connector	Red F-key 120A straight-type	1	
Negative terminal connector	Black F-key 120A straight-type	1	
CAN resistor	RJ45-CAN-120, Pin4&5	1	
Grounding cable	L1000mm	1	
Communication cable to inverter	L5000mm/RJ45 plug at both sides, PIN3&4&5&6	1	
Parallel communication cable	L2000mm, RJ45 Plug at both sides, PIN3&4&5&6	1	
RS485 cable	L2000m	2	
User Manual	/	1	
Warranty Card	/	1	

Table 4-9-1 Packing list







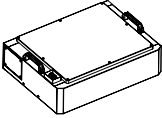

Name	Specification	Quantity	Image
<b>Package B</b>			
ESS-BM-51.2-100CPB-S	690*525*170	1	
Flat head Phillips screws	/	1	
<b>Package C</b>			
Expansion Base	690*525*93	1	
Expansion cover	690*525*200	1	
Power cable	L600mm	2	
Communication cables	/	1	
Grounding cable	L2050mm	1	
Fixing bracket	Fix to the wall	2	
Expansion Bolt	M6*80	4	

Table 4-9-2 Packing list

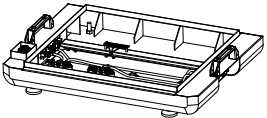
Model	Battery System Capacity(kWh)	Configuration	Dimension (mm)	Weight (KG)
BS30	30.72	A+B*6	690*525*1275	308
BS35	35.84	A+B*7	690*525*1445	356
BS40	40.96	A+B*8	690*525*1615	404
BS46	46.08	A+B*9+C	1680*525*1105	464
BS51	51.20	A+B*10+C	1680*525*1105	512
BS56	56.32	A+B*11+C	1680*525*1275	560
BS61	61.44	A+B*12+C	1680*525*1275	608

## 4.6 Equipment installation

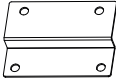
### CAUTION!

1.If more than 8 battery modules are to be installed,you are advised to install them in two columns.

2.One battery column (8 Battery + 1 BPU&Base) is about 1615 mm in height. Please maintain a clearance of 300mm above the BDU. Namely, ensure that the distance between the floor and the ceiling is greater than 1915 mm for the

convenience of installation and better heat dissipation . If the height is not enough,you are advised to install them in two columns.

3.The system should be installed with the help of at least 2 grown-up males.

4.If the use of a conduit is required, please install the bushing to the reserved hole before installing the expansion screw.



## Installation Preparation

- Make sure that the environment meets all technical requirements.
- Prepare equipment and tools for installation.
- Confirm that the DC breaker is in the OFF position.

### DANGER!

The battery system is a high-voltage DC system. Ensure that installation area of Enerstack100 is stable and reliable.

Please confirm that the battery system is switched off before connecting. Electric shock and damage to the inverter may be caused if the battery is connected directly without being switched off.

Otherwise, the system cannot work properly. The voltage of the battery is too high, please pay attention to self-protection during measurement.



## Mechanical Installation

### Step 1: installing the battery base

- Place the base in the designated position. Adjust the base support legs to make the base stable and level.

**Note:** The standard base is suitable for scenarios where a single battery cluster is installed in two rows. If your battery cluster only needs single-row installation, you need to adjust the internal wiring of the base, as shown in the figure below.

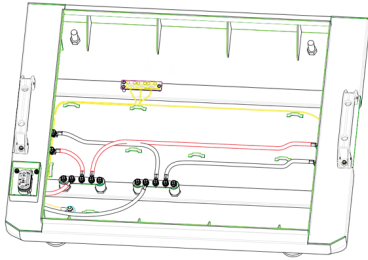

Figure 4-10 Base for two rows

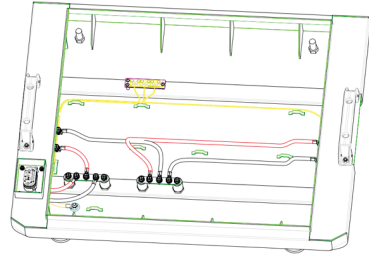

Figure 4-11 Base for single row

### Step 2: Install the battery pack.

- Place the Battery Module onto the base, ensuring that the locating pins of the Battery with the locating points on the base.

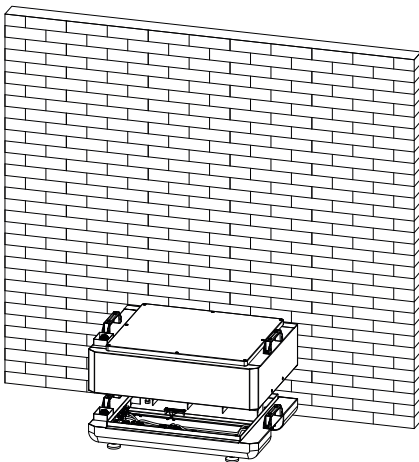

Figure 4-12 Install the battery pack

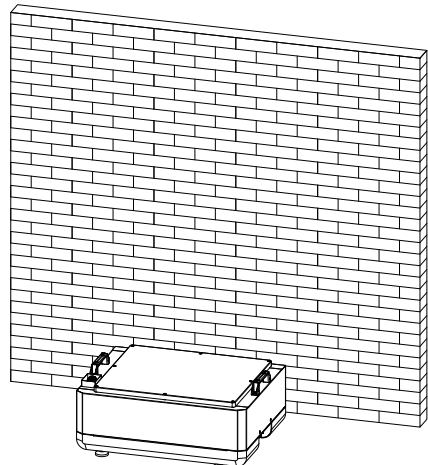

Figure 4-13 Install the battery pack

**Step 3:** Repeat steps 2 until the required batteries and BPU are installed.

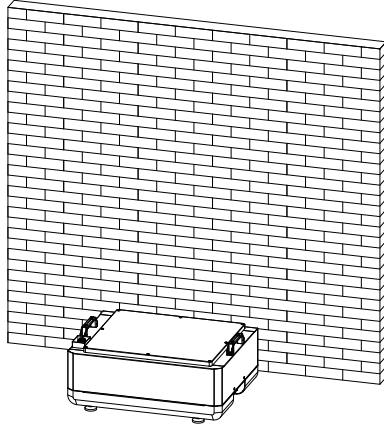

Figure 4-14 Installed the battery BPU

**Step 4:** Installed hanging ear.

- Mark the hole positions using a marker.
- Drill holes at the marked positions to a depth of 90 mm.
- Hanging ears are installed on the left and right sides respectively and locked to the wall with expansion screws(M6x80).
- Use two M5\*12 screws to fix the left and right Hanging ears to the chassis respectively.

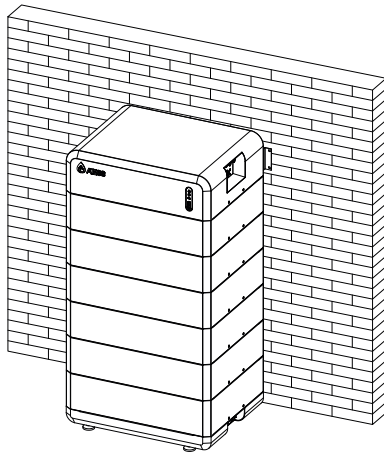

Figure 4-15 Installed the hanging ear

## Expansion package installation

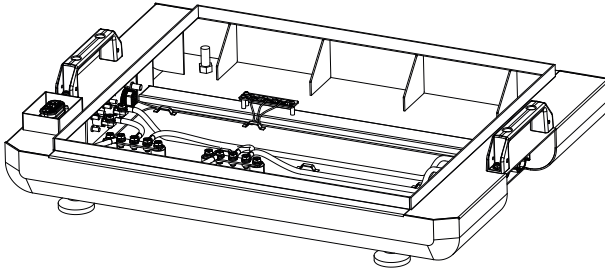

Figure 4-16 Expansion base

**CAUTION!**



If the number of battery packs in a single cluster is greater than 8, it is recommended to use an expansion base for installation. The expansion base is also a standard base suitable for two-row installation, so it can be used directly without any change.

**CAUTION!**



Install according to the minimum distance in Figure 3-1.

**DANGER!**



The Extended cover must be exclusively used with the expansion-labeled base.

**CAUTION!**



The following illustrations depict the correct and incorrect connection methods. Please strictly follow the installation direction of the positive and negative poles as shown in the diagram, otherwise it may cause a short circuit in the battery.

**CAUTION!**



The positive and negative screws need to be tightened. Otherwise, poor contact may lead to heating and trigger a fire.

### Step 5: Cable connection.

- Install communication cables.
- Install the serial cable.
- Install grounding cables.



#### CAUTION!

The color of the cable plug should be consistent with the socket. Otherwise, it may cause a short circuit in the battery.

### Step 6: Install the battery module & top cover

Refer to Step 1&2&3&4.

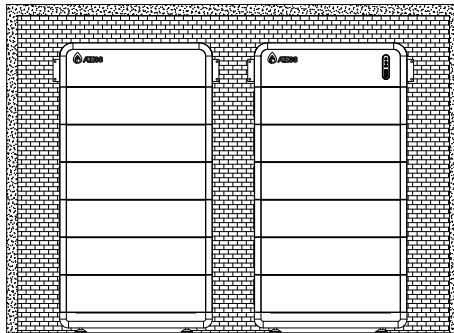

Figure 4-16

### Battery system self-test

- Switch on the DC breaker of the BDU.

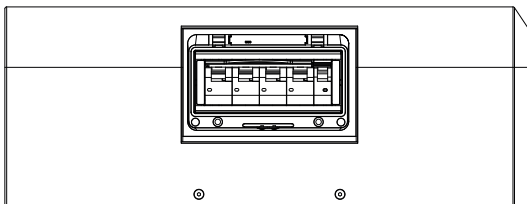

Figure 4-17

- Press the “ON/OFF” button to turn on the BPU. When the power indicator light turns on..., it means the BPU has been turn on.

- Check the system output voltage.

Use a multi-meter to measure the output voltage on the positive and negative ports of the BPU.

The output voltage should conform to the voltage range in the table “Figure 3-1 Battery energy storage system nameplate” .

- Turn the POWER ON knob to OFF, battery shutdown.

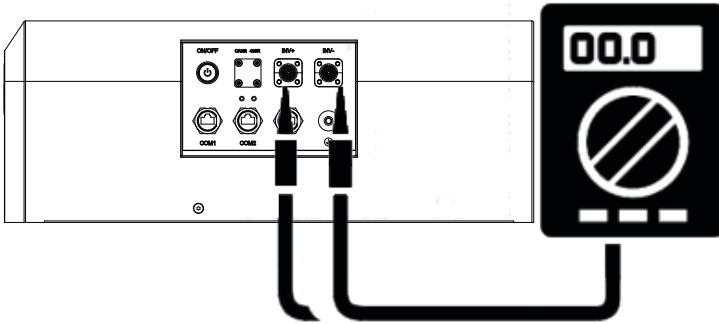

Figure 4-18

- Switch the BPU DC BREAKER to OFF position.

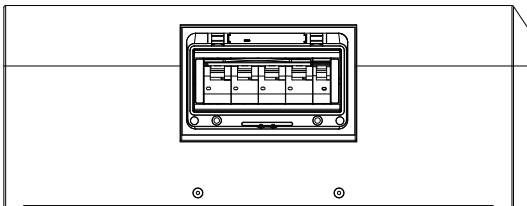

Figure 4-17

## Connecting inverter

- Connect the power cable to the BPU.

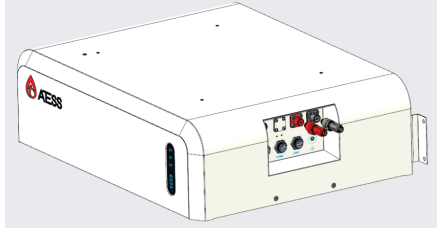

Figure 4-19

- Connect the power cable to the inverter.

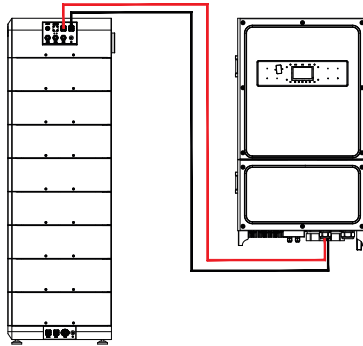

Figure 4-20

- Connect the communication cable between inverter and battery.

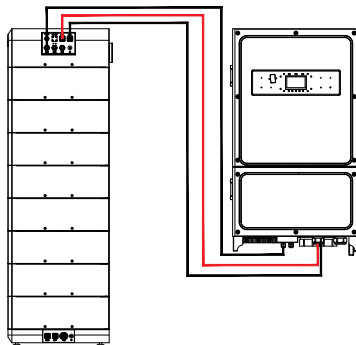

Figure 4-21

## Installation of grounding wire

- Grounding After the system installation is completed. There is a touch down point at the top of the BPU, as shown in the figure below.

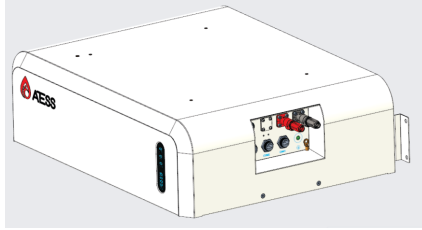

Figure 4-22

## Parallel system

- The parallel connection of the Enerstack100 series and all other related work are only allowed by professional and qualified electricians.

The total voltage difference between clusters is less than 20V; SOC of each cluster should be 100% and time interval between newly added cluster and existing cluster should be less than 3 years.

Maximum 15 Enerstack100 clusters are allowed to be connected in parallel. For parallel operation, the communication cable can only be used with the CAN cable table.

The general configuration diagram of the Enerstack100 in parallel connection is as under. Take three clusters for example.

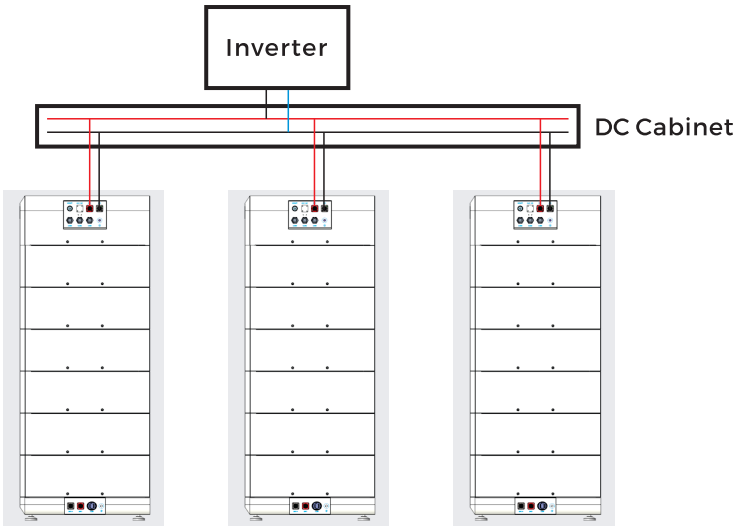

Figure 4-23

## Communication cable connection between Enerstack100 and Enerstack100

- For multi cluster parallel systems, the communication line connection between clusters is Host's Parallel OUT to the second cluster's(Slave) Parallel IN and so on.Then connect a 120  $\Omega$  CAN resistor to the port of the host parallel IN.Ensure the stability of CAN communication.

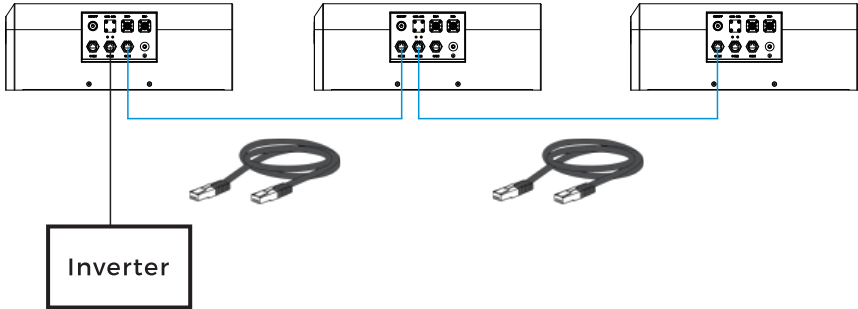

Figure 4-24

### CAUTION!

Choose the correct communication cable.



PIN	Color
1	/
2	/
3	Yellow
4	Red
5	Black
6	Blue
7	NC
8	NC

PIN	Color
1	/
2	/
3	Yellow
4	Red
5	Black
6	Blue
7	NC
8	NC

## 4.7 Battery Capacity Description

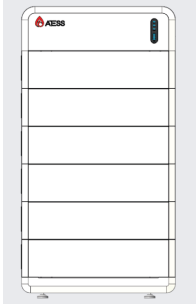

30.7kWh

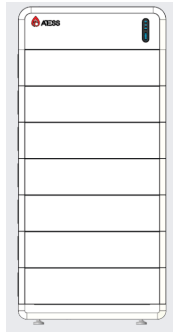

35.8kWh

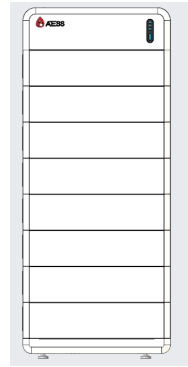

41.0kWh

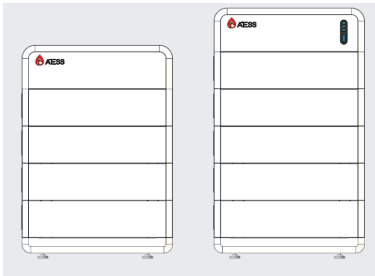

46.1kWh

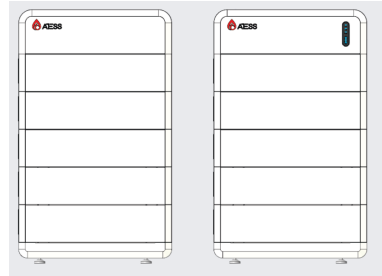

51.2kWh



56.3kWh



61.4kWh

## 5 Maintenance

### 5.1 Troubleshooting

#### DANGER!

The battery system is a high-voltage DC system. Ensure that the installation area of the STACK100 Pro is stable and reliable.



Please confirm that the battery system is switched off before connecting. Electric shock and damage to the inverter may be caused if the battery is connected to the inverter directly without being powered off.

Otherwise, the system cannot operate properly. The voltage of the battery is too high, please pay attention to self-protection during measurement.

NO.	Problem	Possible Reason	Solution
1	Pressing the "WAKE" button does not turn on the device, and the "D" light remains off.	The BDU DC breaker is not switched on.	Switch the BDU DC breaker on.
		The ON/OFF switch of the BDU is not switched on.	Switch the ON/OFF switch on.
		The battery voltage is severely low (<100V) or damaged.	Contact the battery manufacturer for further inspection.
2	Pressing the "WAKE" button turn on the device, the "D" light will turn on, but the display status of the light is yellow or red.	Improper placement of batteries and BDU during installation, resulting in misalignment of blind insertion pins.	Check the blind insertion pin and reset the misplaced blind insertion pin.
		Battery system protection.	Charge the battery to leave protection mode or contact the battery manufacturer for further inspection.

NO.	Problem	Possible Reason	Solution
3	The battery has no voltage output.	Battery changes into over-discharged.	Charge the battery to leave protection mode.
		Communication failure with inverter.	Check if the connection of the communication cable and PIN definition are correct.
		Inverter has an error.	Check for inverter errors and restore the inverter.
4	Battery Shutdown.	BDU DC circuit breaker open circuit.	Switch the BDU DC breaker on.
		Battery changes into over discharged.	Charge the battery to leave protection mode.
		Battery is in sleep mode.	Press and hold the WAKE button for approx. 15s.
5	SOC jump during battery charging and discharging process.	The battery system has not undergone full charge calibration for a long time.	Press and hold the WAKE button for approx. 15s.
		Inconsistent SOC of battery module.	The system performs 10 ~ 50 full charge balancing cycles (depending on the SOC difference of the module, the number of full charge balancing will vary); or fully charge each battery module separately with BDU and DC power supply.
		Differences in battery cell consistency or damage.	Contact the battery manufacturer for further inspection.

## 5.2 Replacement of Main Components

### Replacing the Battery Controller (BDU)

Turn off the entire battery system. Ensure that the negative and positive terminals are de-energized.

- Turn the POWER ON knob to OFF, battery shutdown.
- Switch the BDU DC BREAKER to OFF position.

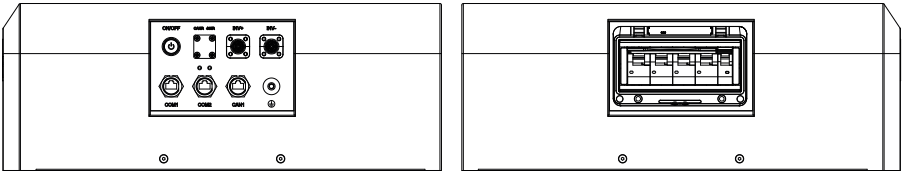

- Disconnect the connecting cable.
- Remove the 4 screws on the BDU and remove the BDU from the system.
- Exchange BDU. Then fix it with 4 screws.
- After replacing the new BDU, the battery self-test needs to be performed again (Refer to P21 Battery system self-test).

## 5.3 Battery Maintenance



### DANGER!

Battery maintenance should only be carried out by professional and authorized persons.  
Turn off the battery system first carrying out maintenance.

#### Voltage check:

[Periodical maintenance] Check the voltage of the battery system with the monitoring software. Check whether the system voltage is normal. For example: Check whether the single cell voltage is out of range.

#### Voltage check:

[Periodical maintenance] Check the SOC of the battery system with the monitoring software. Check whether the SOC of the batteries is normal.

#### Cable check:

[Periodical maintenance] Visually inspect all cables of the battery system. Check whether the cables are broken, aging or loose.

**Balancing:**

[Periodical maintenance] The battery system will become unbalanced if it has not been charged fully for a long time. Solution: Perform balancing maintenance (fully charge) every 10~12 month. Generally this maintenance progress needs to be completed when external devices such as the monitoring software and battery and inverter have proper communication.

**Output relay check:**

[Periodical maintenance] Under low load (low current), check the output relay OFF and ON condition; listen if the relay clicks, which means that it switches off and on normally.

## 6 Storage

For long-term storage (more than 3 months), the battery cells should be stored within the temperature range of 5 to 45o C, relative humidity <65% and non-corrosive gases.

The battery module should be stored within the temperature range of 5 to 45oC, dry, clean and well ventilated environment. The battery should be charged to 50 - 55% SOC before storage.

We recommend activating the battery system (discharge and charge) every 10~12 months.

**CAUTION!**

The lifespan of the battery will be greatly reduced if you do not follow above instructions to store the battery for a long term.

**CAUTION!**

Corresponding to the battery system that has been installed and used normally, it is necessary to regularly fully charge the battery to calibrate the SOC. It is recommended to fully charge and calibrate at least once every 2 weeks.

## 7 Shipment

The battery module is pre-charged to 30% SOC or according to customer requirements before shipment. The remaining capacity of battery cells is determined by the storage time and condition after shipment.

The battery modules meet UN38.3 certificate standard.

In particular, special rules for the carriage of goods on the road and the current dangerous goods law, specifically ADR (European Convention on the International Carriage of Dangerous Goods by Road), as amended, must be observed.



**SHENZHEN ATESS POWER TECHNOLOGY CO.,LTD**

GROWATT-ATESS Industrial Park, No.23 Zhulongtian Road, Shuitian Community,  
Shiyan Street, Baoan District, Shenzhen

Tel: +86 755 2998 8492

Web: [www.atesspower.com](http://www.atesspower.com)

Email: [info@atesspower.com](mailto:info@atesspower.com)

Revised date: 2026-06-09